

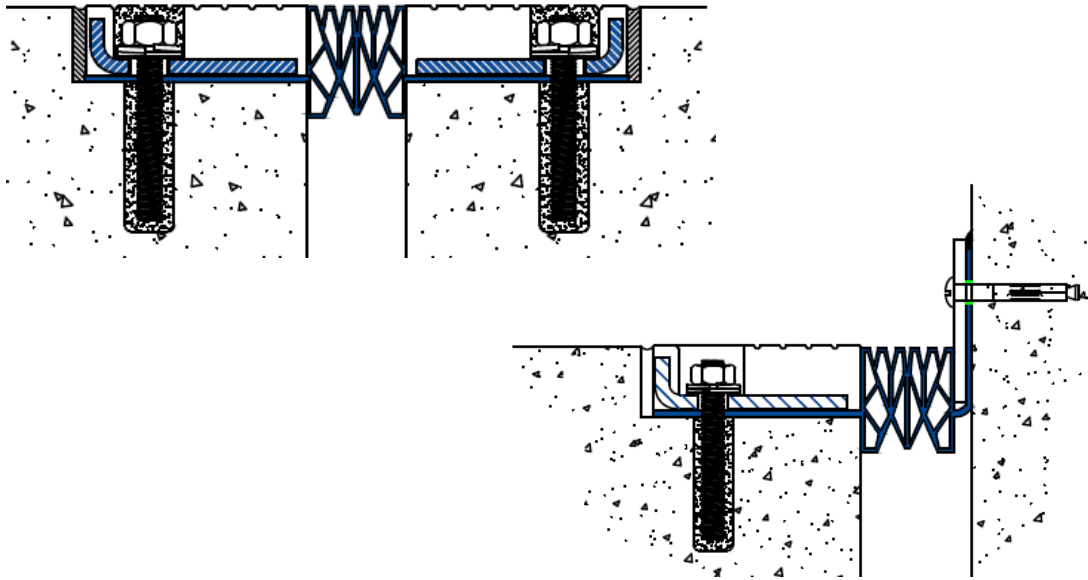

BUILDING TRUST



Installation Procedure



Wabo®ElastoFlex - EFJ/EFJ-C Horizontal Expansion Joint System

The following installation procedure is very important and must be fully understood prior to beginning any work. To ensure proper installation and performance of expansion joint system the following actions must be completed by the installing contractor. Failure to do so will affect product warranty.

- 1) Carefully read and understand installation procedure. Contact Emseal's Technical Service Department at (508-836-0280) for product assistance.
- 2) Inspect all shipments and materials for missing or damaged components and hardware. Contact Customer Service at (508-836-0280) with Emseal's order number and invoice for prompt assistance.
- 3) Inspect substrate or adjacent construction for acceptance before beginning work. Report unacceptable construction to the project manager for scheduled repair work.
- 4) Review Emseal shop drawings for project specific detailed information if Engineering services were purchased at time of order.

Health & Safety

During the installation of any Sika Emseal product, appropriate personal protective items should be worn at all times, including but not limited to the following:

- Proper work clothing
- Safety glasses
- Safety boots
- Gloves
- Hard hat



Local rules and regulations regarding safe work environments and health should be followed.

Product Components

The following components are required for the installation of this product:

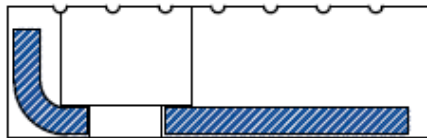

Premolded Steel Reinforced Elastomeric Anchor Block (P/N 2914)

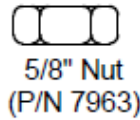

5/8" Nut (P/N 7963)



5/8" Lockwasher (P/N 7729)



1/4" x 2" Lg Threaded * Concrete Anchor (P/N 6912)



5/8" Washer (P/N 7549)



5/8" Dia. x 4-1/2" Lg. A36 Threaded Anchor (P/N 6519)
Hilti HY 150 Epoxy Adhesive Cartridge (P/N 6521)



NP1 Sealant (P/N 2826)

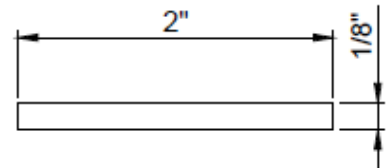

Corner Wall Mount Plate * P/n: 9015



Components shown below vary in size depending on model of system:

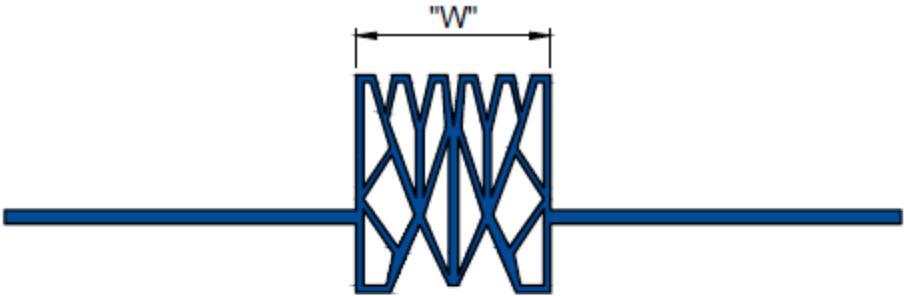

Elastomeric Elastoflex Gland
Note: Webbing Varies with Model

Model	Seal Width "W"	P/N
EFJ-225/225C	2 1/4"	1224
EFJ-300/300C	3"	1230
EFJ-400/400C	4"	1228
EFJ-600/600C	6"	1229

*Denotes: Components used for Corner Condition



Installation

1 Blockout: Blockout in the deck, sidewalk & curbs, shall be constructed to dimensions shown on drawings. All air bubbles 1/4" and larger shall be pointed with an epoxy grout. The bottom shall be parallel with the deck surface.

Surface Preparation: To properly achieve adhesion of sealants, all oils, grease, tars, coatings, asphalt and/or other contaminants must be removed. Sandblasting is the preferred method of cleaning the blockout. After cleaning, blow out all residue with compressed air.

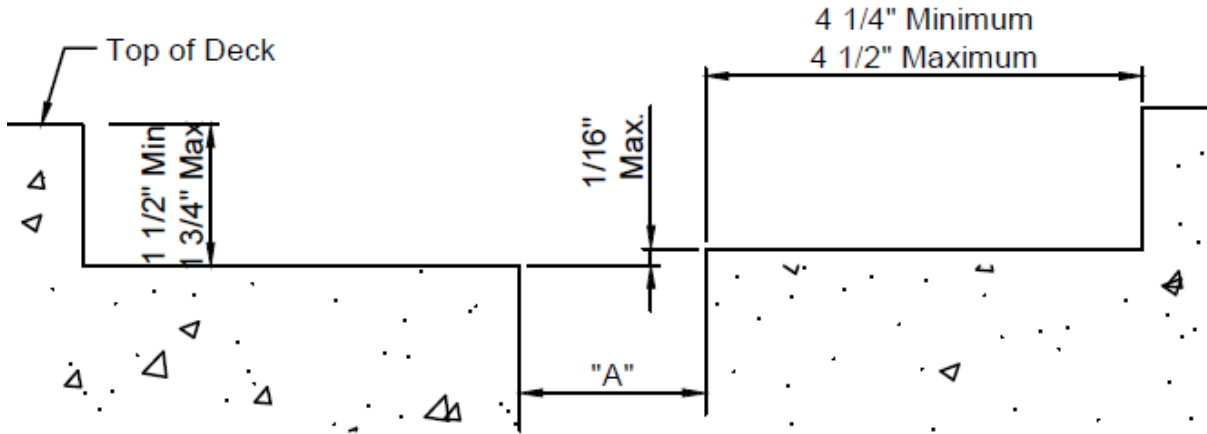

2 Anchor Bolt Installation: Utilize the actual elastomeric anchor blocks as templates to locate adhesive anchors. It is recommended to start at either a curb or miter and to utilize quick clamps to hold the blocks together. At the tongue and groove connections, align the anchor block with the throat opening to locate gauge line of anchors.

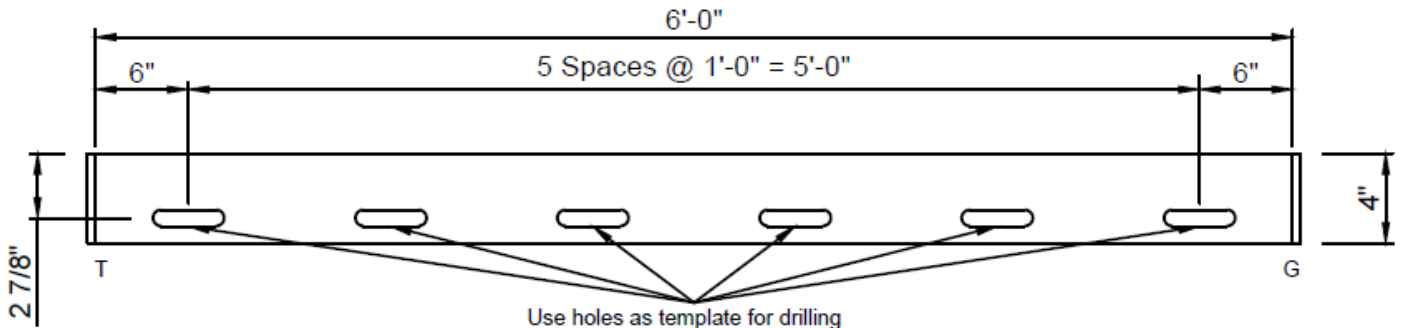

T - Tongue
G - Groove

Plan View
Standard Elastoflex Anchor Block



3

Set blocks flush with edge of joint opening. Drill pilot holes at anchor locations into concrete structure and remove EPDM blocking. Once the EPDM blocking has been removed, follow anchor manufacturer's guideline for using the correct diameter-sized drill bit. After drilling holes, use compressed air or a vacuum to clean out holes.

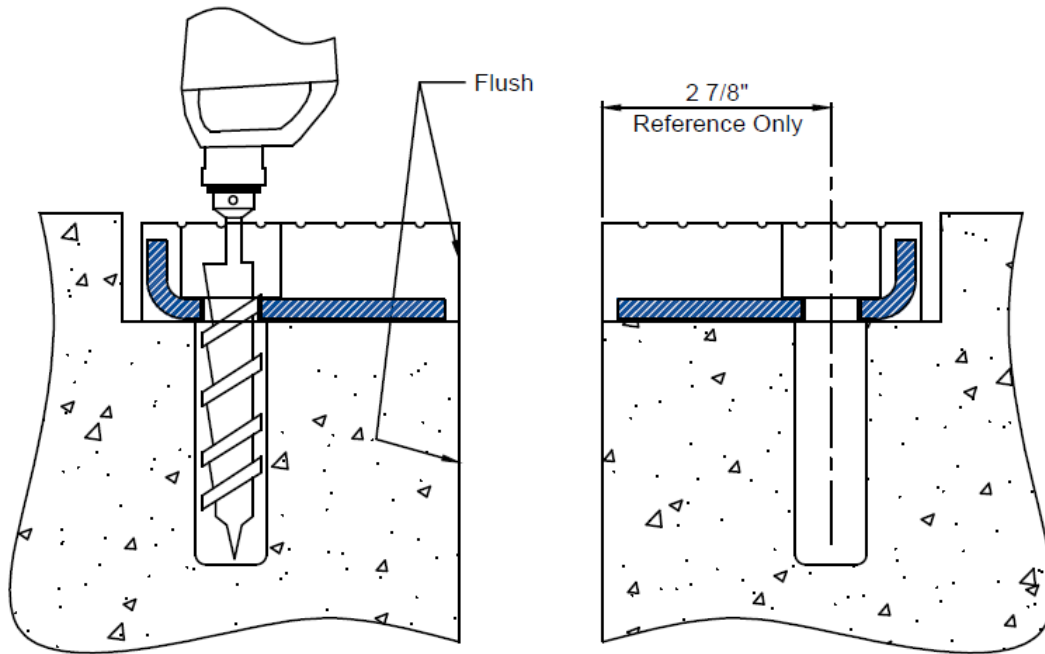

BUILDING TRUST



4

Cast in place anchor bolts. Care shall be taken to ensure that the anchors are set at right angles to the blockout.

Note: Hole size, depth, drill bits, installation procedure and cure times shall be in strict accordance with epoxy manufacturer's (Hilti) guidelines.

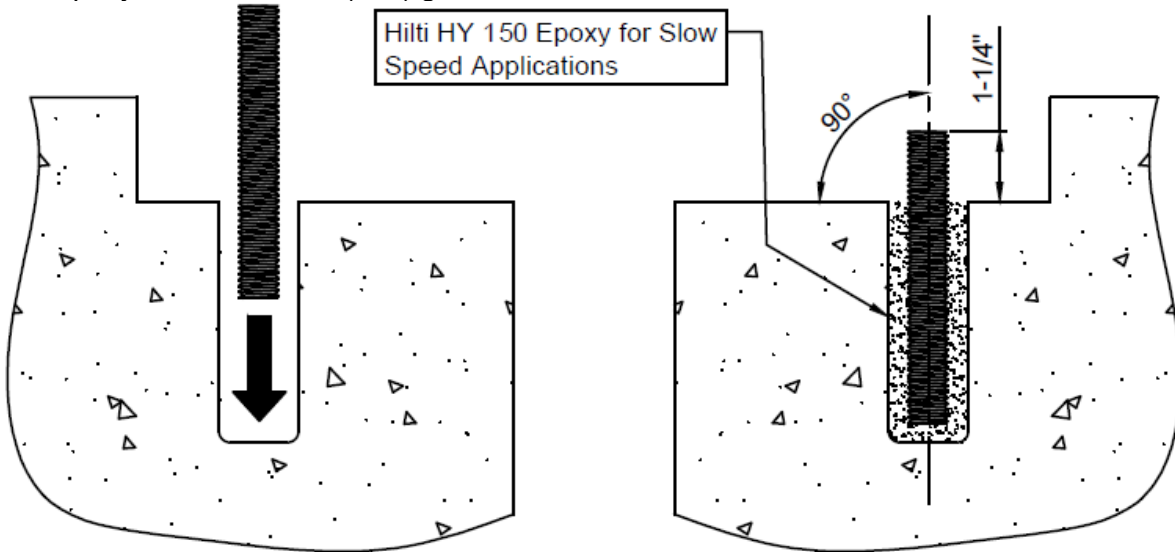

5

Apply a serpentine bead of NP1 Sealant. Sealant should be spread by a 1/8" grooved trowel to ensure a nice, even spread on the blockout as shown. Follow immediately to the next step, before Sealant cures. **Note:** It is recommended you work in short increments: 12 ft.

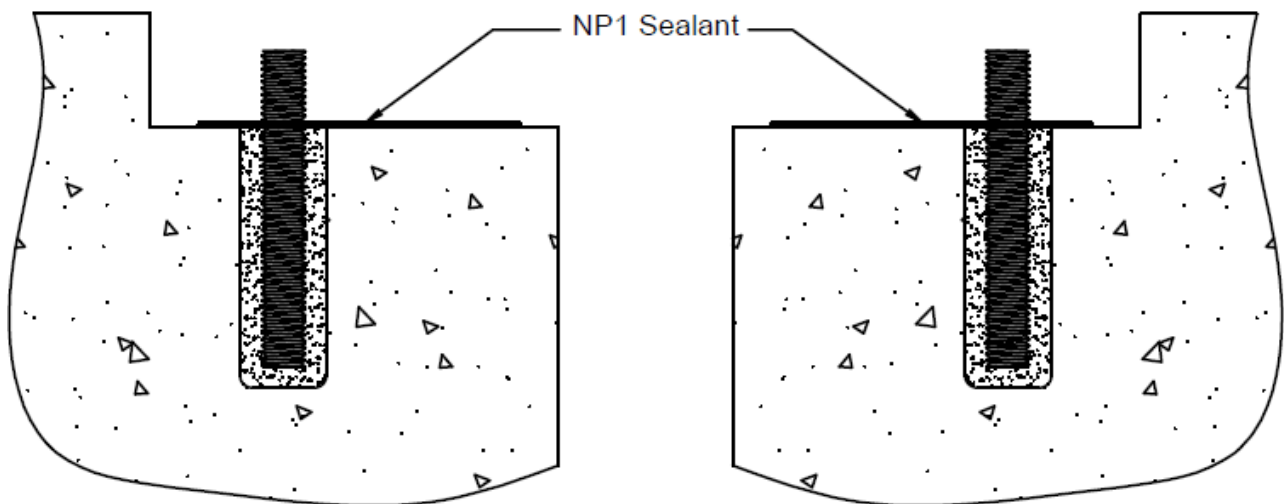

6

Compress seal and insert into the expansion opening, pushing seal flaps firmly into Sealant bedding on base of blockout. Follow immediately to the next step.

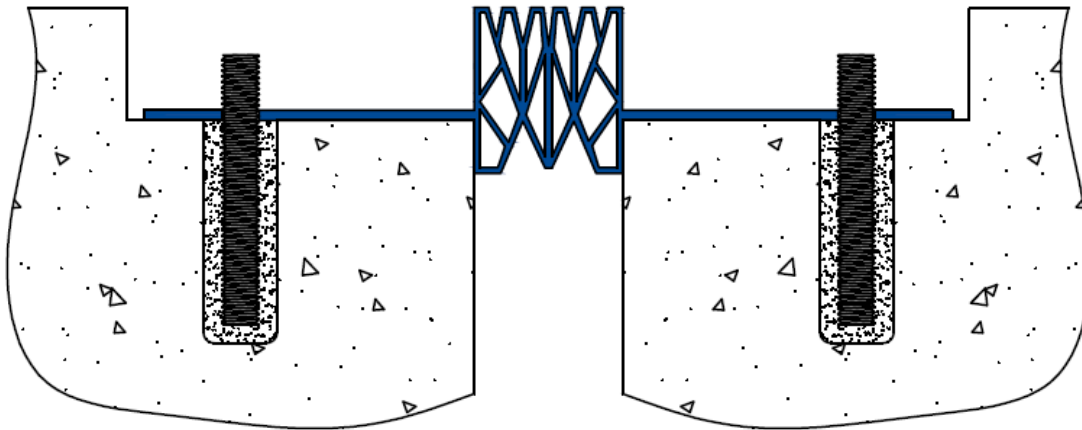

7

Before Sealant cures, place the anchor blocks into proper position. Utilize a thin wall socket (for clearance) to install nuts, torquing to **(50ft/lbs for Slow Speed and 65ft/lbs for High Speed applications)**. Follow procedure shown for tongue and groove splice connections and application of Sealant. Repeat process until all blockouts are placed. Retorque approximately one hour after initial placement; all hardware shall be retorqued to 50ft/lbs.

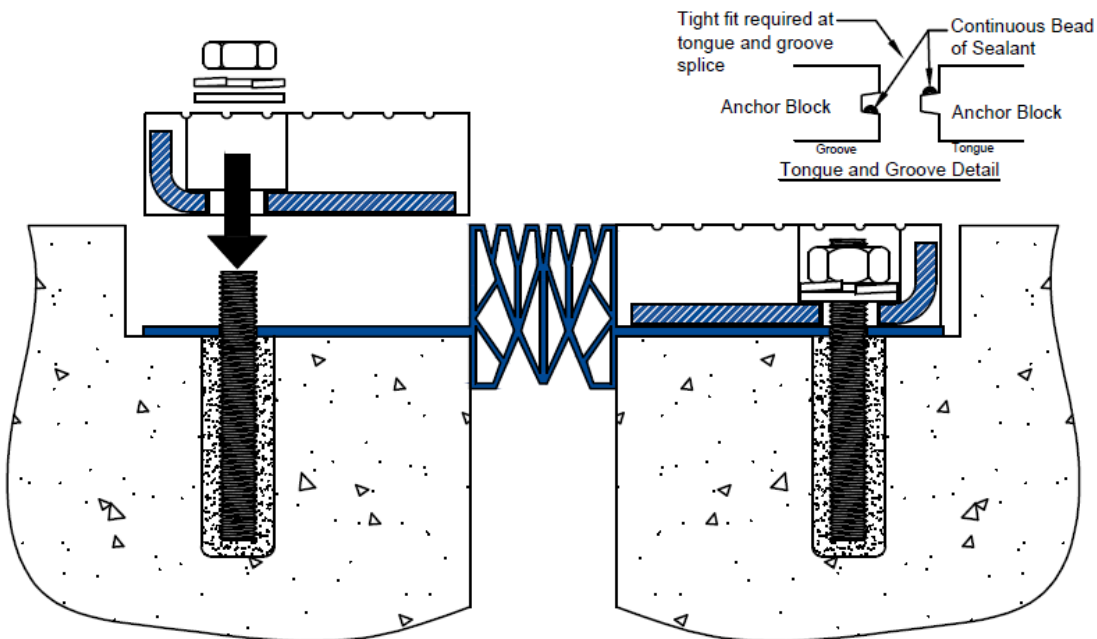

BUILDING TRUST



8

With all sections installed to the satisfaction of the engineer:

Edge Void Sealant - Utilizing compressed air, clean edge void cavity and fill with Sealant. Sealant should be pressed into edge void, as shown, with a masonry pointing trowel edge roller tool to ensure proper sealing. After Sealant is installed, make sure the Sealant surface is smooth by using a grouting trowel.

Bolt Cavities - Fill in bolt holes with the supplied Wabo@Crete II Elastomeric Concrete with 50% of the supplied aggregate (30lbs.). It is recommended that the immediate area around the bolt cavities be covered with duct tape prior to the installation of Wabo@Crete II.

Note: Follow preparation and installation instructions in the material specifications.

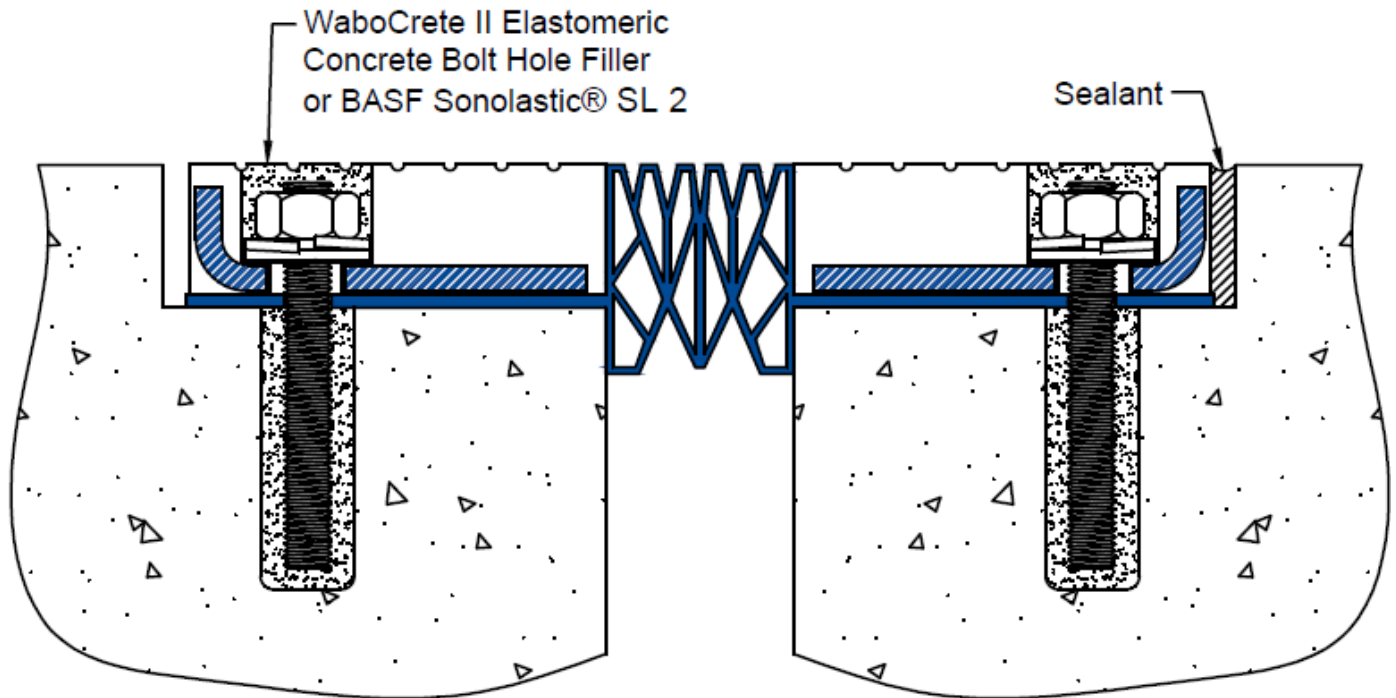

BUILDING TRUST



9

Fold up flap of the seal, insert Corner Mount Bracket between seal and flap as shown below. Set gland in throat opening. Use anchor block to prepare floor side of opening, as shown in steps 3 & 4. For installing wall side, use Corner Mount Bracket as a template and drill locations for concrete anchors. Before applying Sealant, ensure gland is level, and all holes have been drilled.

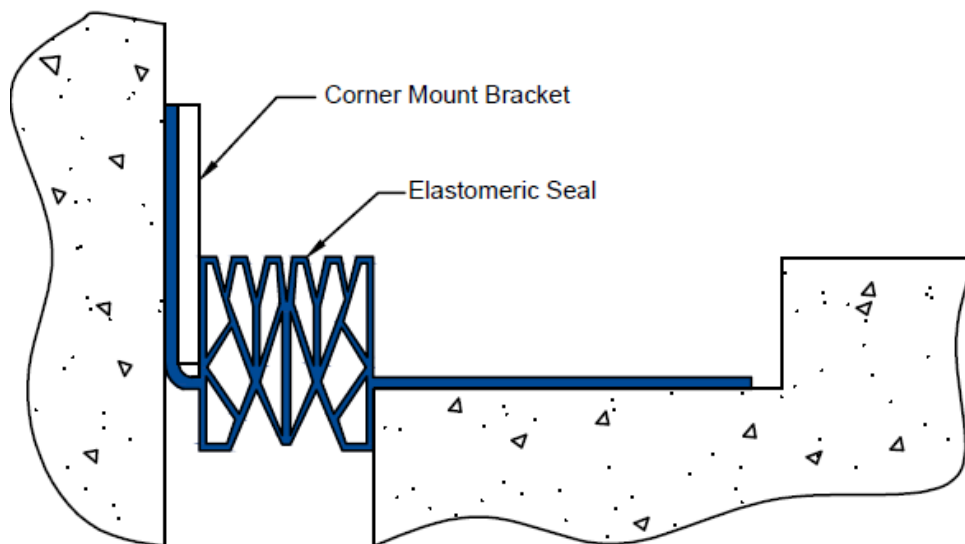

10

Apply Sealant to back of seal flap. Sealant should be spread by a 1/8" grooved trowel to assure a nice even spread on the back face of the seal, as shown. Attach Corner Wall Mount Bracket to wall using anchor bolts. Trim off excess seal flap, flush with top of Corner Wall Mount Bracket.

Place bead of Sealant along top of wall mount. Install gland to floor as shown in steps 5, 6, 7, and 8.

Edge Void Sealant - Utilizing compressed air, clean edge void cavity and fill with Sealant. Sealant should be pressed into edge void, as shown, with a rounded edge roller tool to ensure proper sealing.

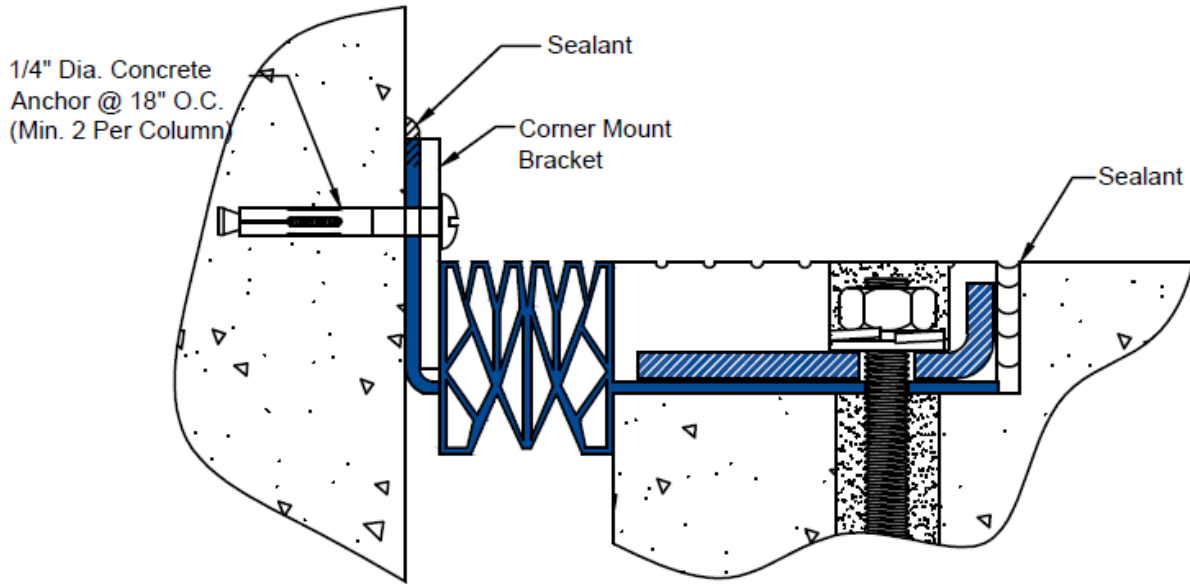

Curb Details

Curb area installations (if applicable) - undercut seal as indicated on the drawings at curb area and continue installing seal, utilizing procedures in steps 5 and on.

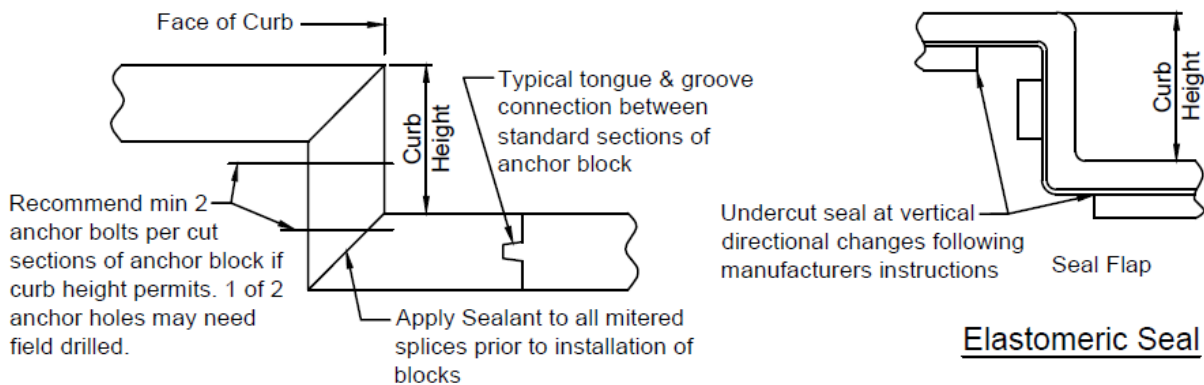

EFJ Seal Splice Details

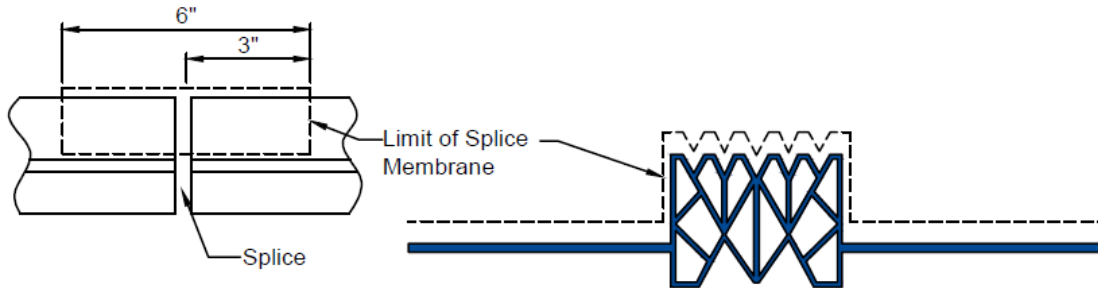

Seal Splice Instructions

1. Cut ends of the ElastoFlex seal with a sharp knife and a miter box (supplied by contractor). Ensure cuts are clean, straight and square.
2. Clean ends of seal with a solvent to remove any foreign material.
3. Brush apply PP Primer (part #2717) to both seal ends to be joined together at splice.
4. Apply Aron Alpha 241F adhesive (part #2716), as specified by the manufacturer, to all internal and outer webs of the two seal surfaces to be bonded.
5. Apply pressure, bringing the two surfaces in tight contact immediately upon completing application of the adhesive. Hold in place for approximately one to two minutes to allow adhesion.
6. Re-check quality of all splices and apply additional adhesive (if required) to ensure proper miter or splice.
7. Contact manufacturer for clarification of above procedure (if required) prior to proceeding with splicing seal profile. It is usually recommended to allow 15 minutes time before installing spliced seal. Care shall be exercised, as it takes 24 hours for adhesive to fully cure.
8. Apply 1/32" thick thermoplastic splice membrane with adhesive for additional protection (Optional) and reinforcement of splice at straight-run butt splices only.

Recommended Equipment for Wabo®Crete Mixing

- Abrasive blasting equipment
- 3/4" Heavy Duty Drill (1 hsp - Low RPM)
- 3/8" Hand Drill
- (2) "egg-beater" style mixing paddles
- Large Paddle (4" to 6")
- Small Paddle (2")
- Roll of 15lb Roofing Paper
- (2) Clean 5 gallon plastic buckets
- (4) Clean 1 gallon plastic buckets (For bonding agent)
- (8) 2" disposable paint brushes (For Bonding agent)
- Rubber gloves
- (8) 2" Margin trowels
- Misc. hand tools and extension cords



Yield Calculations for full unit of Wabo®Crete:

- One unit of Wabo®Crete II will yield .60 cu. ft.
- One unit of Wabo®Crete II = One US half gallon Part A, One gallon Part B, and one 60 lb Container of aggregate. the formula for calculating volume is: (length in feet x width in inches x depth in inches) / 86.4
= Number of units of Wabo®Crete needed to complete the job.

Example:

Based on a blockout size of 3-1/2" wide x 3/4" deep x 30' long:

The calculation would be: (.0304 x 30)= .91 units. This calculation is for only **ONE** side of the bockout.

Curing of Wabo®Crete:

Wabo®Crete II is an ambient cure material. Cure times are, therefore, temperature dependant. Suggested cure times are listed below:

Cure Time:	21° - 32°C(70°-90°F) - 1 to 1 1/2 Hours
(Open to Traffic)	10° - 21°C(50°-70°F) - 1 1/2 to 2 Hours
	4° - 10°C(40°-50°F) - 2 to 3 Hours

Information provided herein, including but not limited to, any drawing, design, photograph, graphic, or statement(s) ("Materials") are proprietary and the property of Sika Emseal. ("Company"). Reproduction, translation, or reduction to any electronic medium or machine readable form, in whole or part, is strictly prohibited, except for the express purpose for which it has been furnished, without prior written consent of Company. All Materials contained herein are provided by Company for information purposes only. Company reserves the right to amend or withdraw any information contained in the Materials without notice. All technical or other advice by Company, whether verbal or written, concerning products, or the use of products in specific situations ("Advice") is given by Company and is used at the User's own risk.

Sika Emseal
25 Bridle Lane, Westborough, MA 01581 USA
Phone: 508-836-0280 / Fax 508-836-0281
www.emseal.com

Rev. 1.0 04-02-2024



BUILDING TRUST

