



BUILDING TRUST



## Installation Procedure

---

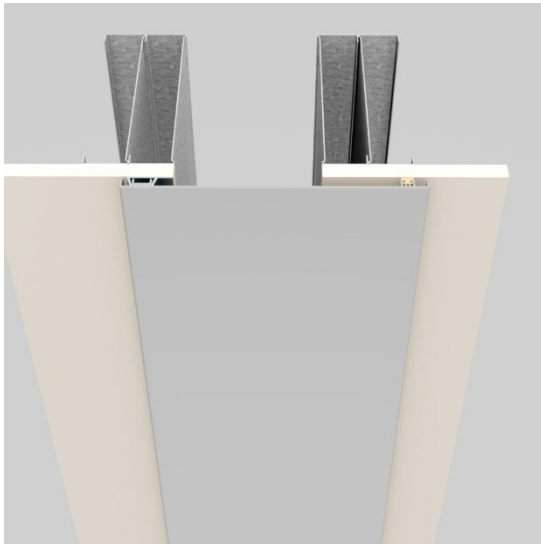

Wall to Wall

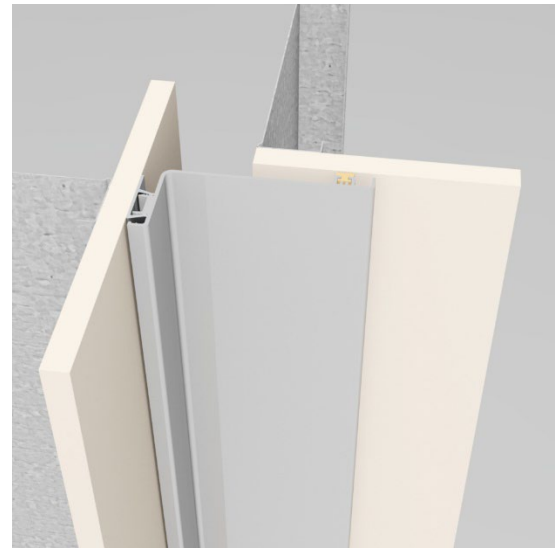

Wall to Corner

## Wabo®FastWall EWH & EWH-C

Interior Wall and Ceiling Expansion Joint System

The following installation procedure is very important and must be fully understood prior to beginning any work. To ensure proper installation and performance of expansion joint system the following actions must be completed by the installing contractor. Failure to do so will affect product warranty.

- 1) Carefully read and understand installation procedure. Contact Sika Emseal's Technical Service Department at 508-836-0280 for product assistance.
- 2) Inspect all shipments and materials for missing or damaged components and hardware. Contact Customer Service at 508-836-0280 with Emseal's order number and invoice for prompt assistance.
- 3) Inspect substrate or adjacent construction for acceptance before beginning work. Report unacceptable construction to the project manager for scheduled repair work.
- 4) Review Sika Emseal shop drawings for project specific detailed information if Engineering services were purchased at time of order.

# Health & Safety

During the installation of any Sika Emseal product, appropriate personal protective items should be worn at all times, including but not limited to the following:

- Proper work clothing
- Safety glasses
- Safety boots
- Gloves
- Hard hat



Local rules and regulations regarding safe work environments and health should be followed.

# Product Components

The following components are required for the installation of this product:

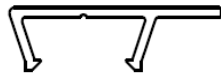

Base Extrusion  
(P/N 9748)



PVC Gasket  
(P/N 2838)

Components shown below vary in size depending on model of system:

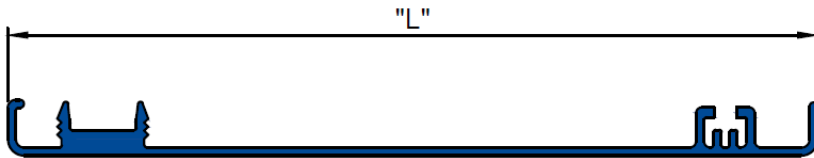

Aluminum Cover  
(See Chart Below for P/N and Size)

Model	Part #	Dim "L"
EWH-100	9742	4 1/4"
EWH-200	9743	5 3/4"
EWH-300	9744	7 1/4"
EWH-400	9749	8 1/4"

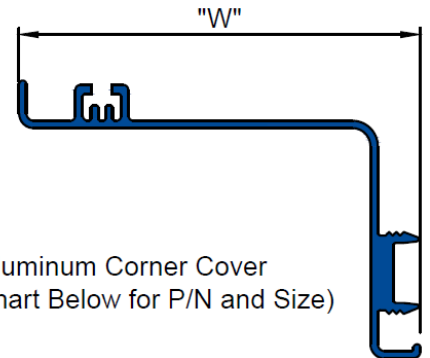

Aluminum Corner Cover  
(See Chart Below for P/N and Size)

Model	Part #	Dim "W"
EWH-100C	9745	2 25/32"
EWH-200C	9746	4 9/32"
EWH-300C	9747	5 25/32"
EWH-400C	9750	6 3/4"



BUILDING TRUST



# Installation

- 1** Position base extrusion onto wall, flush with edge of joint opening.

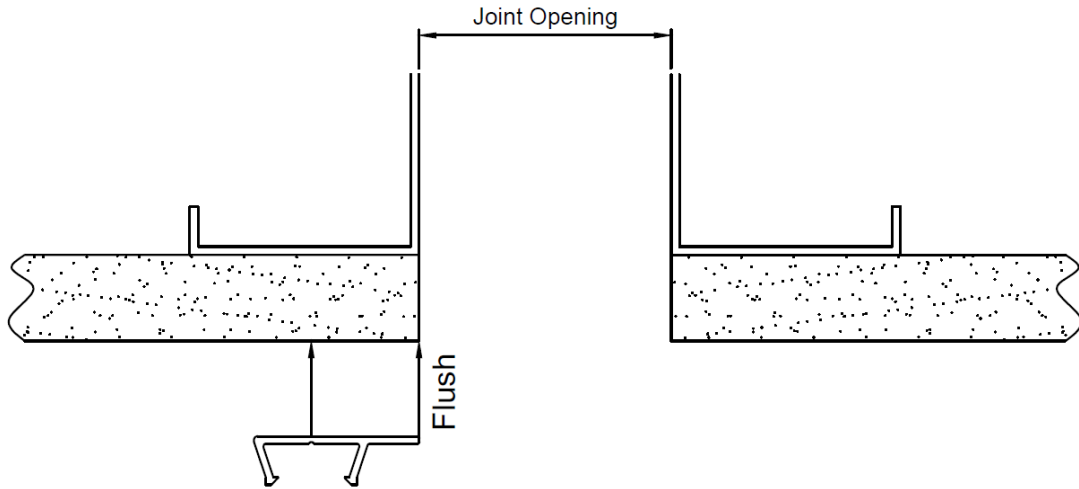

- 2** Align and drive drywall screw through base extrusion into wall construction at the specified anchor spacing.

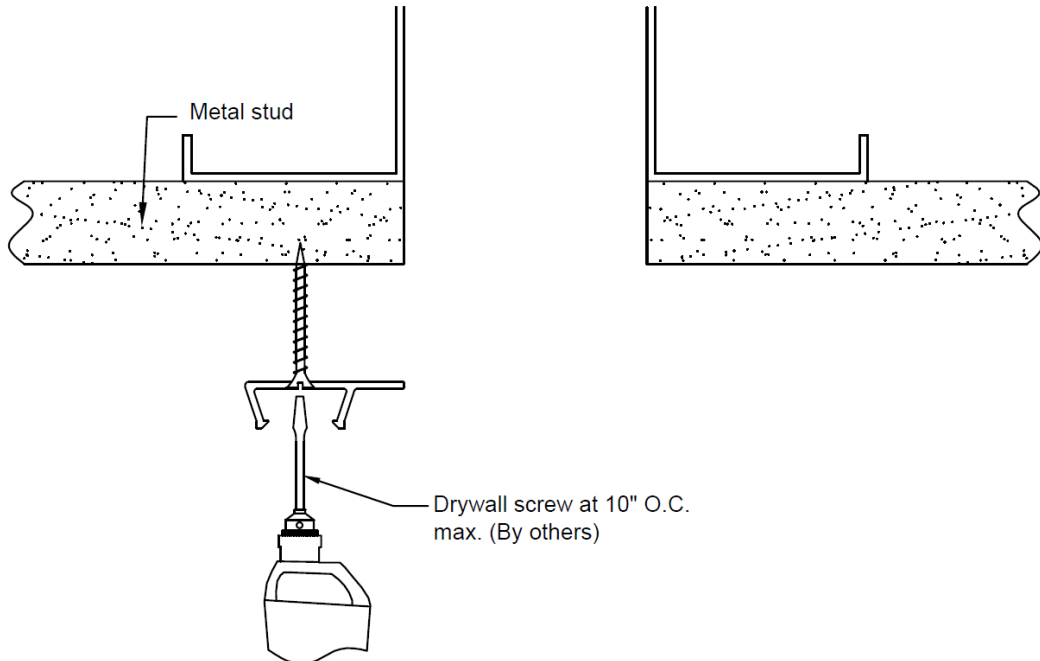

---

**3** Slide PVC Gasket into cover.



---

**4** Align cover with base extrusion. Slowly and carefully snap aluminum cover into base extrusion.

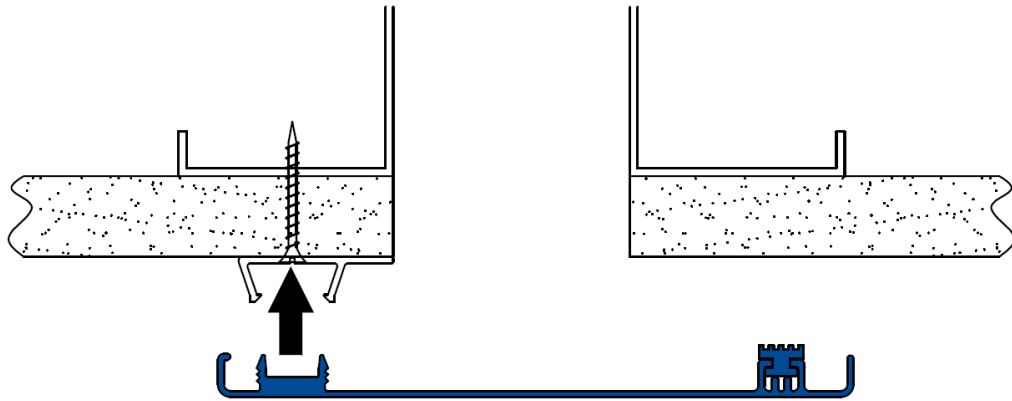

# Corner Condition

- 1 Position base extrusion onto wall as shown. Ensure top of the base extrusion is  $5/8$ " away from other wall.

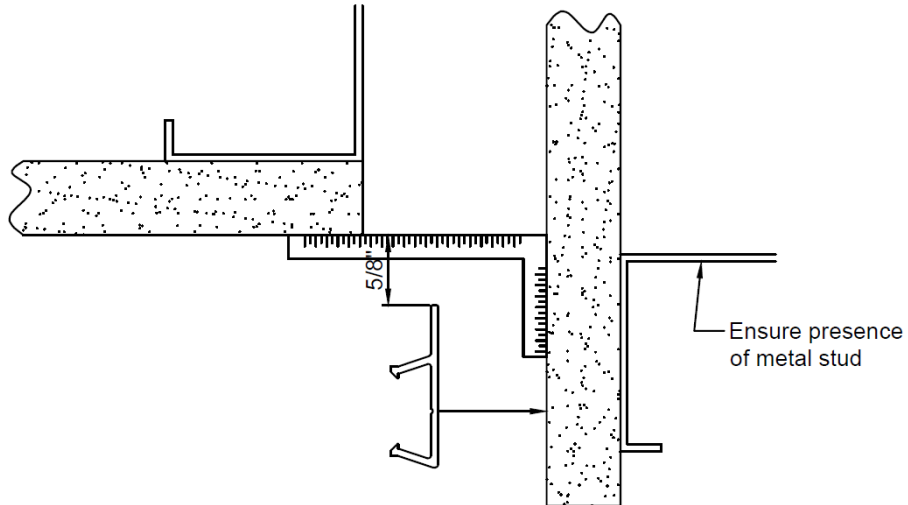

- 2 Drill hole through metal wall stud for dry wall using screw gun. Align and drive drywall screw through base extrusion into wall construction at the specified anchor spacing.

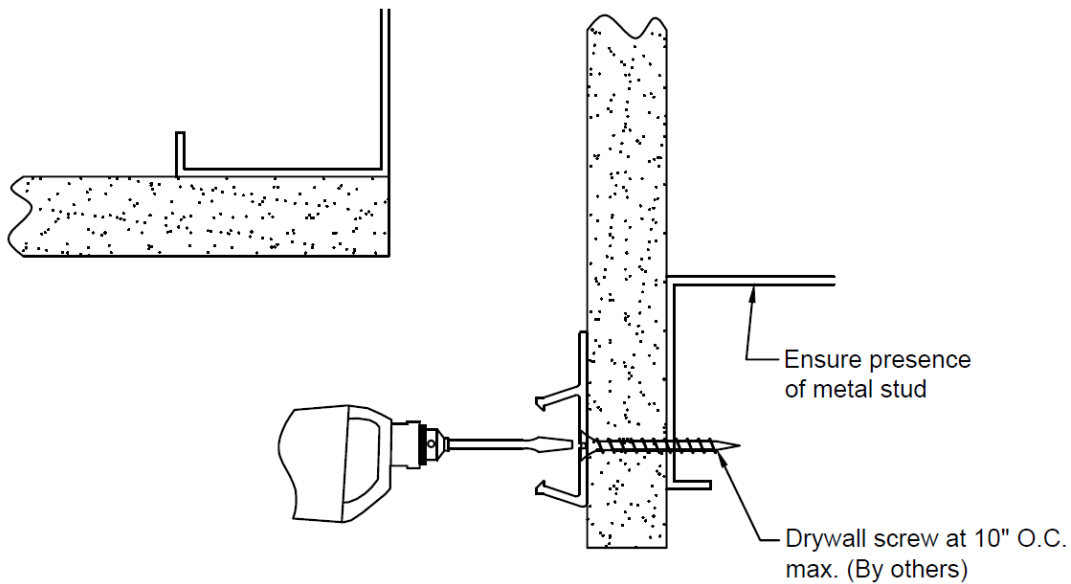

3

Slide PVC Gasket into cover.

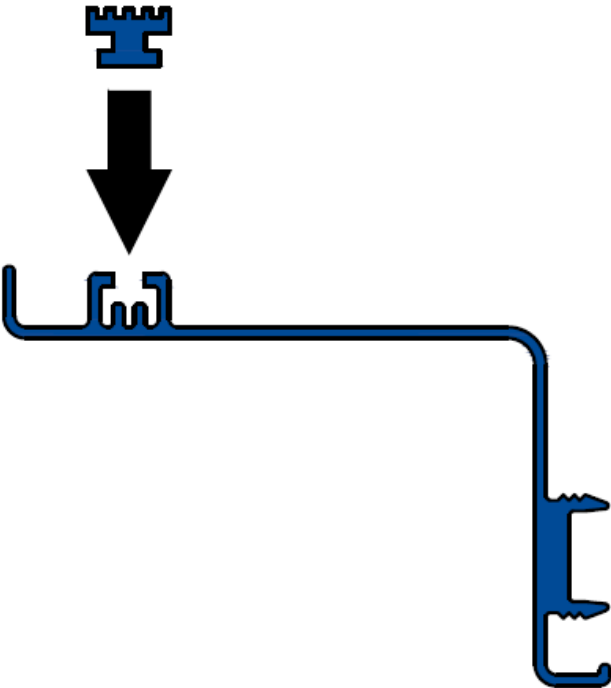

4

Align cover with base extrusion. Slowly and carefully snap aluminum cover into base member.

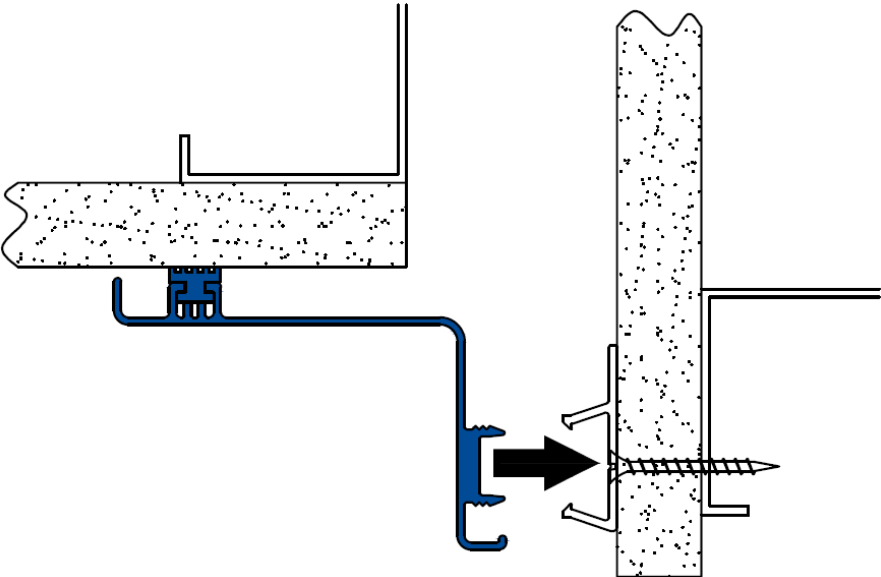

Information provided herein, including but not limited to, any drawing, design, photograph, graphic, or statement(s) ("Materials") are proprietary and the property of Sika Emseal. ("Company"). Reproduction, translation, or reduction to any electronic medium or machine readable form, in whole or part, is strictly prohibited, except for the express purpose for which it has been furnished, without prior written consent of Company. All Materials contained herein are provided by Company for information purposes only. Company reserves the right to amend or withdraw any information contained in the Materials without notice. All technical or other advice by Company, whether verbal or written, concerning products, or the use of products in specific situations ("Advice") is given by Company and is used at the User's own risk.

Sika Emseal  
25 Bridle Lane, Westborough, MA 01581 USA  
Phone: 508-836-0280 / Fax 508-836-0281  
[www.emseal.com](http://www.emseal.com)

Rev. 1.0 04-02-2024



**BUILDING TRUST**

