



BUILDING TRUST



Wabo®RoofCover (RFC)

Roof Expansion Joint

Features	Benefits
<ul style="list-style-type: none"> • Versatile movement 	Accommodates multi-directional seismic and thermal movement
<ul style="list-style-type: none"> • Rugged and durable 	Eliminates concerns of falling ice, snow maintenance, ozone, and ultra-violet rays.
<ul style="list-style-type: none"> • Universal components 	Offers solutions for a variety of conditions.



DESCRIPTION:

Wabo®RoofCover is engineered for roofs with expansion joints subject to multi-directional thermal and seismic movement. The heavy-duty metal cover provides durability in accommodating ice, snowloads and occasional maintenance foot traffic while providing maximum resistance to UV rays and moisture infiltration. Internally, Wabo®RoofCover utilizes integral weather seals and a primary moisture barrier to prevent the elements of weather from penetrating the building opening.



RECOMMENDED FOR:

- Seismic expansion joint systems for projects in:
 - Health-care
 - Transportation
 - Recreation
 - Retail
 - Commercial
 - Educational
 - Other
- Exterior, horizontal expansion control systems on sloped or flat roof structures with cant strips.

PACKAGING/COVERAGE:

- Metal profiles shipped in standard 10 foot lengths with a mill finish.
- Accessories packaged in manufacturer's standard labeled carton.



BUILDING TRUST



TECHNICAL DATA:

Design Information:

Wabo®RoofCover (RFC) can be utilized to accommodate expansion joints in roof applications that have a roofing membrane and tapered cant strips.

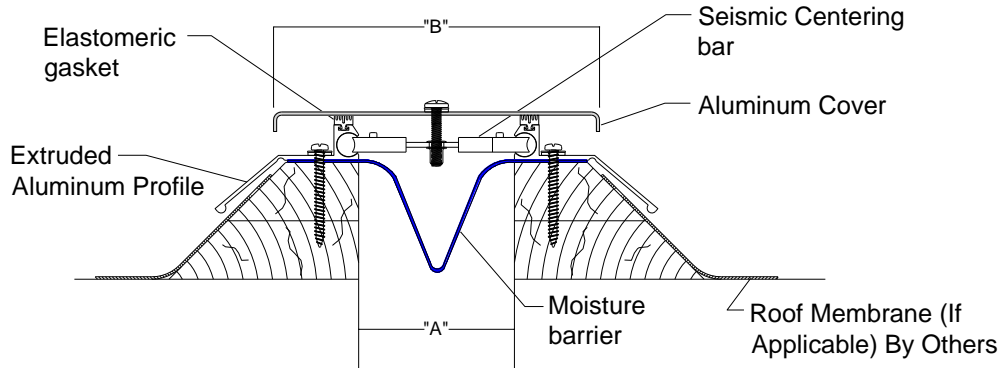

Model RFC

Note: see product sales drawings for additional details

Movement Table

MODEL NUMBER	JT. OPENING "A"		SYSTEM WIDTH "B"		TOTAL MOVEMENT	
	inches	mm	inches	mm	inches	mm
RFC-200	2.0	51	6.38	162	3.00	76
RFC-400	4.0	102	8.38	213	6.00	152
RFC-600	6.0	152	11.38	289	9.00	229
RFC-800	8.0	203	14.38	365	12.00	305
RFC-1000	10.0	254	17.00	432	15.00	381
RFC-1200	12.0	305	19.75	502	18.00	457
RFC-1800	18.0	457	28.75	730	27.00	686
RFC-2400	24.0	610	37.75	959	36.00	914
RFC-200C	2.0	51	3.75	95	3.00	76
RFC-400C	4.0	102	6.75	171	6.00	152
RFC-600C	6.0	152	9.75	248	9.00	229
RFC-800C	8.0	203	12.75	324	12.00	305
RFC-1000C	10.0	254	15.88	403	9.75	248
RFC-1200C	12.0	305	18.88	479	11.75	299
RFC-1800C	18.0	457	27.88	708	17.75	451
RFC-2400C	24.0	610	36.88	937	23.75	603



BUILDING TRUST

Note: see product sales drawings for additional details



PHYSICAL PROPERTIES:

Aluminum Base Member: ASTM B221, Alloy 6061-T6 or 6063-T-5.

Aluminum Shapes: ASTM B209, alloy 5005-H34.

Cover Plate: ASTM B209, alloy 5005-H34. Material thickness shall typically be .080 inch.

Self-Centering Bar: Molded or manufactured incorporating corrosion resistant nylon components.

Moisture Barrier: Fabric reinforced tear resistant clear vinyl. Minimum thickness shall be .026”.

Cover Plate Gasket: EPDM exhibiting a shore “A” hardness of 65 +/-5.

APPLICATION:

INSTALLATION SUMMARY:

- Protect all expansion joint components from damage during installation and protect finished installation from damage from other trades during all work activities.
- Expansion joint systems shall be installed in accordance with manufacturer’s typical details and installation procedures.
- Construction and materials shall be designed to allow for proper installation of system and its components.
- Construct joint openings consistent in width and straight along joint length. Inspect and verify all substrates to be solid and sound prior to work.
- Construct all adjacent floors to be horizontally flat along length and flush across both sides of the opening. Inspect and verify all substrates to be solid and sound prior to work.
- Install appropriate fire barrier system, if required by building code and rated construction. Contact Emseal for recommendations on appropriate fire barrier system.
- Metal components shall be cut to length on job site where required. Components shall be miter cut in the field to conform to directional changes unless otherwise contracted with expansion joint manufacturer.
- All anchor holes shall be field drilled in accordance with manufacture’s drawings.

FOR BEST RESULTS:

- Do not install if the joint’s anticipated movement will exceed the system’s movement range.
- Deliver product in each manufacturer’s original, intact, labeled containers. Protect the work area with appropriate plastic sheeting.
- Do not allow any of the components to freeze prior to installation. Store all components out of direct sunlight in a clean, dry location between 50°F (10°C) and 90°F (32°C). Store off the ground and protect from weather and construction activities.
- Periodically inspect the installed material and repair localized areas as needed. Inspect for loose components and/or hardware, repair as necessary. Consult a Emseal representative for additional information.
- Make certain the most current version of the product data sheet is being used. Please consult the website (www.emseal.com) or contact a customer service representative.
- Proper application is the responsibility of the user. Field visits by Emseal personnel are for the purpose of making technical recommendations only and not for supervising or providing quality control on the jobsite.

RELATED DOCUMENTS:

- Material Safety Data Sheets
- Wabo@RoofCover Specification
- Wabo@RoofCover Sales Drawings
- Wabo@RoofCover Installation Procedure

LIMITED WARRANTY:

Emseal Joint Systems. Ltd. warrants that this product conforms to its current applicable specifications. SIKA EMSEAL MAKES NO OTHER WARRANTY, EXPRESS OR IMPLIED, INCLUDING ANY WARRANTY OF MERCHANTABILITY OR WARRANTY OF FITNESS FOR A PARTICULAR PURPOSE. The sole and exclusive remedy of Purchaser for any claim concerning this product, including, but not limited to, claims alleging breach of warranty, negligence, strict liability or otherwise, is the replacement of product or refund of the purchase price, at the sole option of Emseal. Any claims concerning this product shall be submitted in writing within one year of the delivery date of this product to Purchaser and any claims not presented within that period are waived by Purchaser. IN NO EVENT SHALL SIKA EMSEAL BE LIABLE FOR ANY SPECIAL, INCIDENTAL, CONSEQUENTIAL (INCLUDES LOSS OF PROFITS) OR PUNITIVE DAMAGES. Other warranties may be available when the product is installed by a factory trained installer. Contact your local Sika Emseal representative for details. The data expressed herein is true and accurate to the best of our knowledge at the time published; it is, however, subject to change without notice.

Sika Emseal
25 Bridle Lane, Westborough, MA 01581 USA
Phone: 508-836-0280 / Fax 508-836-0281
www.emseal.com

Rev. 1.1 07-24-2024

