

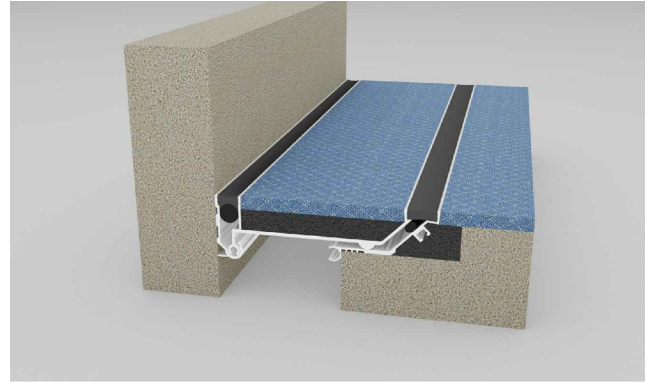

BUILDING TRUST

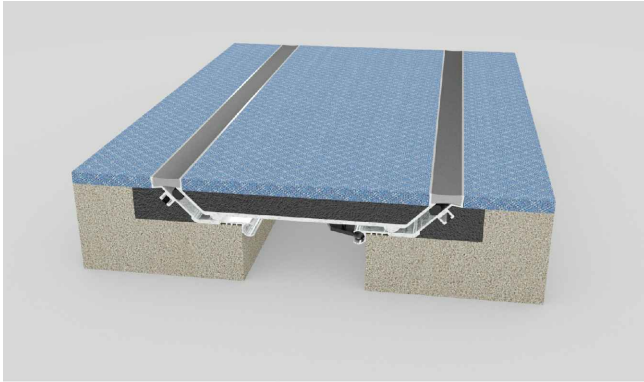

## Installation Procedure



### Wabo® Seismic Pan Model(s) SPJ / SPJ-C Horizontal Expansion Control System

The following installation procedure is very important and must be fully understood prior to beginning any work. To ensure proper installation and performance of expansion joint system the following actions must be completed by the installing contractor. Failure to do so will affect product warranty.

- 1) Carefully read and understand installation procedure. Contact Sika Emseal's Technical Service Department at 508-836-0280 for product
- 2) assistance. Inspect all shipments and materials for missing or damaged components and hardware. Contact Customer Service at 508-836-0280 with Emseal's order number and invoice for prompt assistance.
- 3) Inspect substrate or adjacent construction for acceptance before beginning work. Report unacceptable construction to the project manager for scheduled repair work.
- 4) Review Emseal shop drawings for project specific detailed information if Engineering services were purchased at time of order.

# Standard components

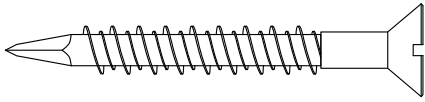

Concrete Threaded  
Anchor #2764  
1/4" x 2-1/4"  
Part No. 6526

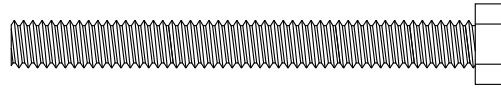

Bolt 1/4" x 2-1/2"  
Part No. 4835



Nut 1/4"  
Part No. 7869

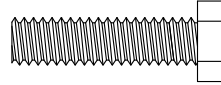

Bolt 1/4" x 1"  
Part No. 4836

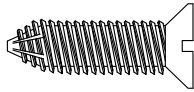

Screw 1/4" x 1"  
Part No. 5634

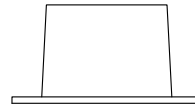

CapPlug W8 Red  
Plastic  
Part No. 4337

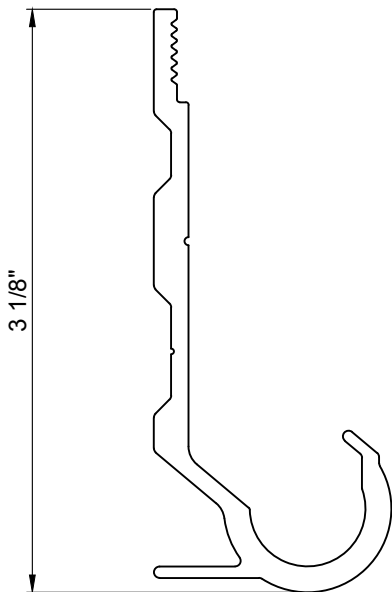

Wall Mount  
Part No. 19610

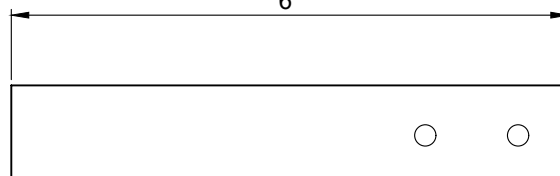

Butt Splice Connector  
Part No. 14050



# Components shown below vary in size depending on model of system

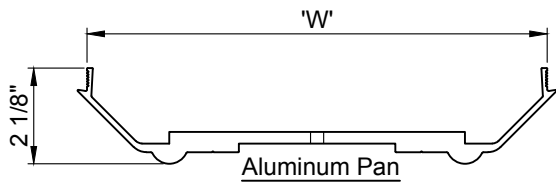

Model #	Part #	'W' dim.
SPJ-200	19656	7.917"
SPJ-400	19650	9.917"
SPJ-600	19652	11.917"
SPJ-800	19626	15.917"
SPJ-1000	19627	17.917"
SPJ-1200	19628	20.917"
SPJ-1600	19617	26.917"
SPJ-1800	19618	31.917"

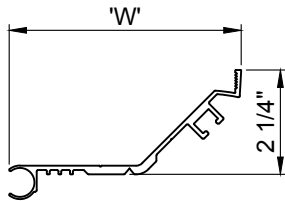

Aluminum Edge Frame

Model #	Part #	'W' dim.
SPJ-400/600	19651	5"
SPJ-800/1000	19609	6"
SPJ-1200	19606	6.50"
SPJ-1600	19607	7.50"
SPJ-1800	19608	9"

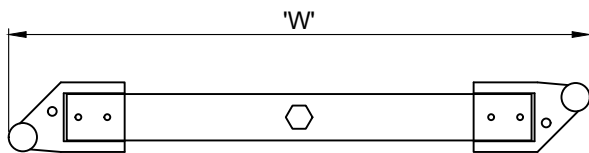

Seismic Centering Bar

Model #	Part #	'W' dim.
SPJ-400	15642	7 3/8"
SPJ-600	15643	12 3/8"
SPJ-800/1000	15630	18 3/8"
SPJ-1200	15631	22 3/8"
SPJ-1600	15603	26 3/8"
SPJ-1800	15604	38 3/8"

Flush Condition

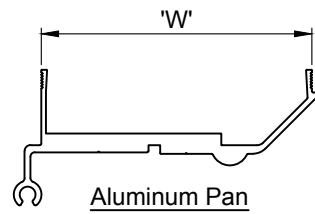

Model #	Part #	'W' dim.
SPJ-200C	19658	3.835"
SPJ-400C	19653	5.835"
SPJ-600C	19654	7.835"
SPJ-800C	19632	10.835"
SPJ-1000C	19633	12.835"
SPJ-1200C	19634	15.835"
SPJ-1600C	19635	20.335"
SPJ-1800C	19636	23.835"

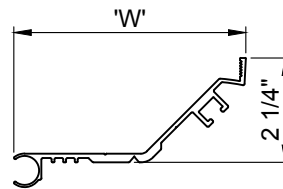

Aluminum Edge Frame

Model #	Part #	'W' dim.
SPJ-400C/600C	19651	5"
SPJ-800C/1000C	19609	6"
SPJ-1200C	19606	6.50"
SPJ-1600C	19607	7.50"
SPJ-1800C	19608	9"

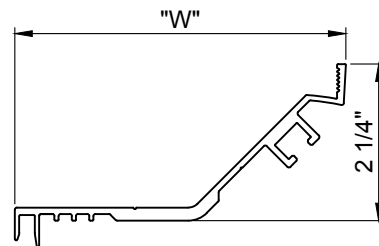

Aluminum Edge Frame

Model #	Part #	'W' dim.
SPJ-200/200C	19657	4 3/4"

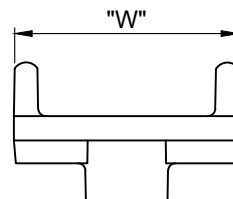

Seismic Centering Bar

Model #	Part #	'W' dim.
SPJ-200	11120	10"

# Installation procedure for flush condition

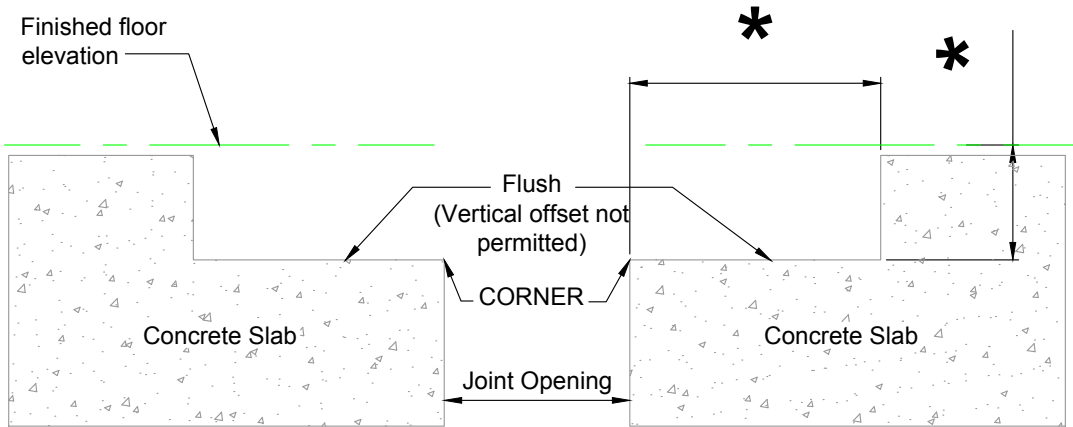

- 1** Prior to beginning work, installer shall inspect opposing concrete slabs, corners and blockouts for acceptability. For repair (if required) refer to step 2, also, measure joint opening for proper size as called for on Emseal shop drawings or Cad detail.  
 \* See Emseal Shop drawings or Cad detail for specific blockout information.

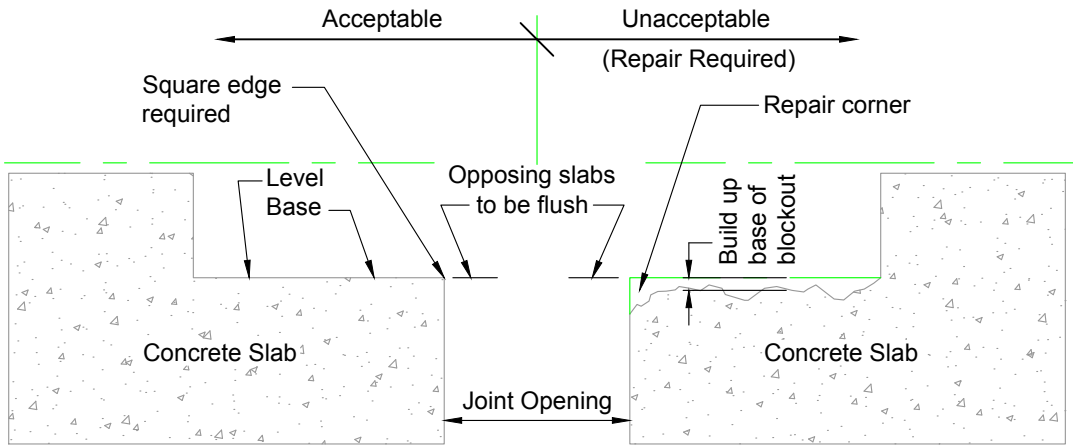

- 2** Repair corner of concrete slab and blockout base following manufacturers written instructions.

Figure 3a.1

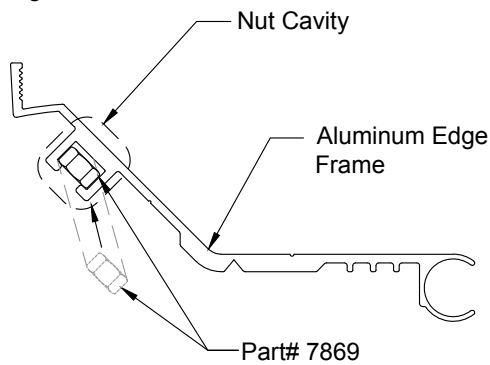
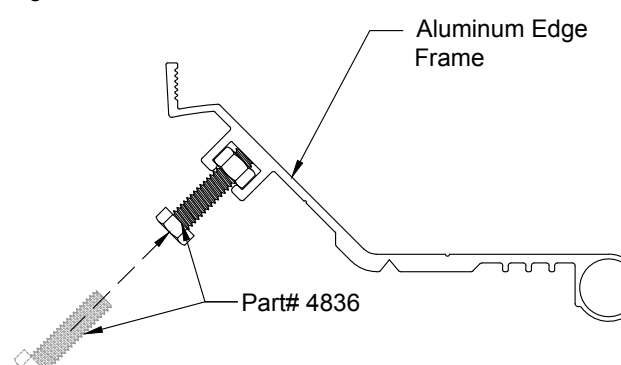
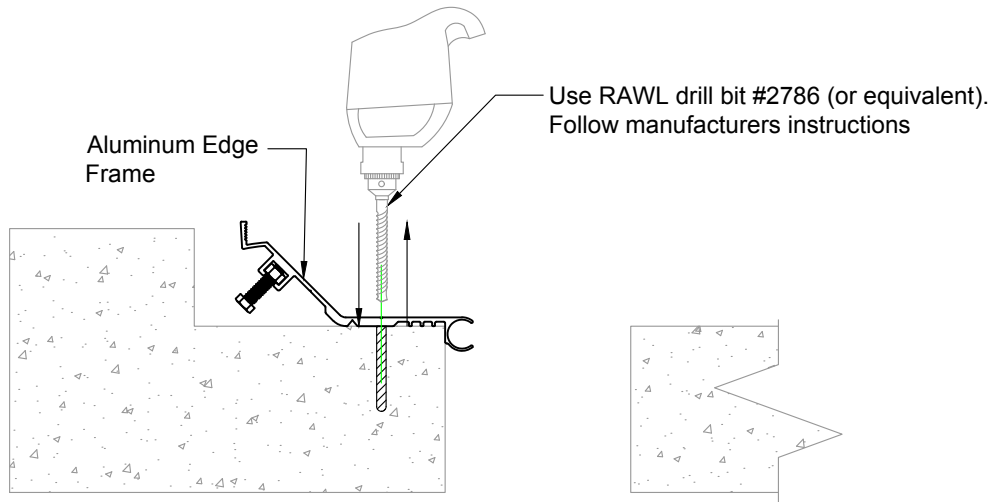

Figure 3a.2



- 3a** Figure 3a.1 - Insert (4) ZINC PLATED NUTS (Part # 7869) into NUT CAVITY of ALUMINUM EDGE FRAME.  
 Figure 3a.2 - Thread Bolt 1/4" x 1" HLN (Part # 4836) into each ZINC PLATED NUT, spacing at 36" on center (starting 6" from either end). Tighten until bolts are secure.



**3b**

Utilizing pre-drilled holes in Aluminum edge frame assembly as a template, drill pilot holes using a 3/16" TAPPER Masonry drill Bit. Use two 5 foot Aluminum Edge frame sections (1 on each side of joint opening) when starting a run of Wabo® Seismic Pan. See step 6.

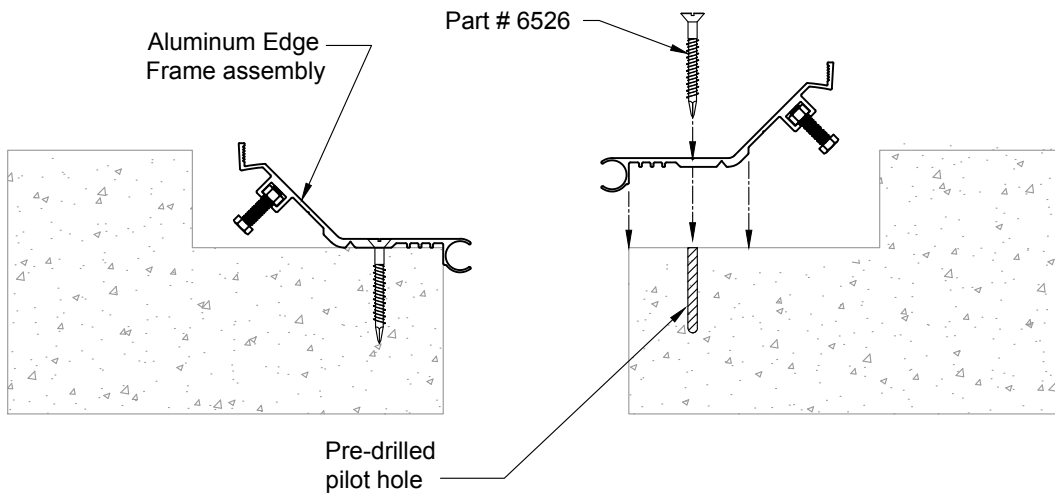

**3c**

Fasten Aluminum Edge Frame Assembly securely using Threaded Anchor Rawl Tapper #2764 1/4" x 2-1/4" (Part No. 6526)

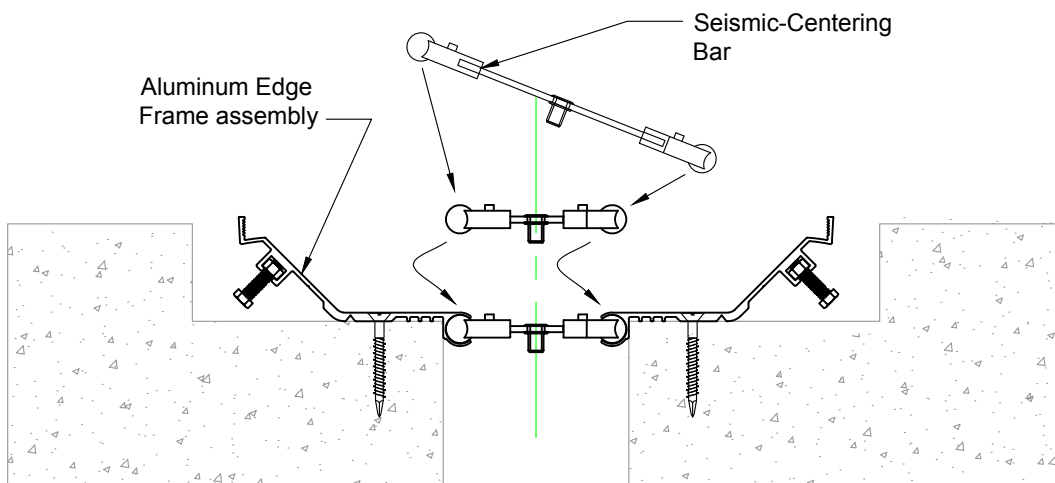

**4**

Insert Seismic-centering bars into circular aluminum cavity as work progresses from step 3c. Space bars at 18" o.c. See plan next page.

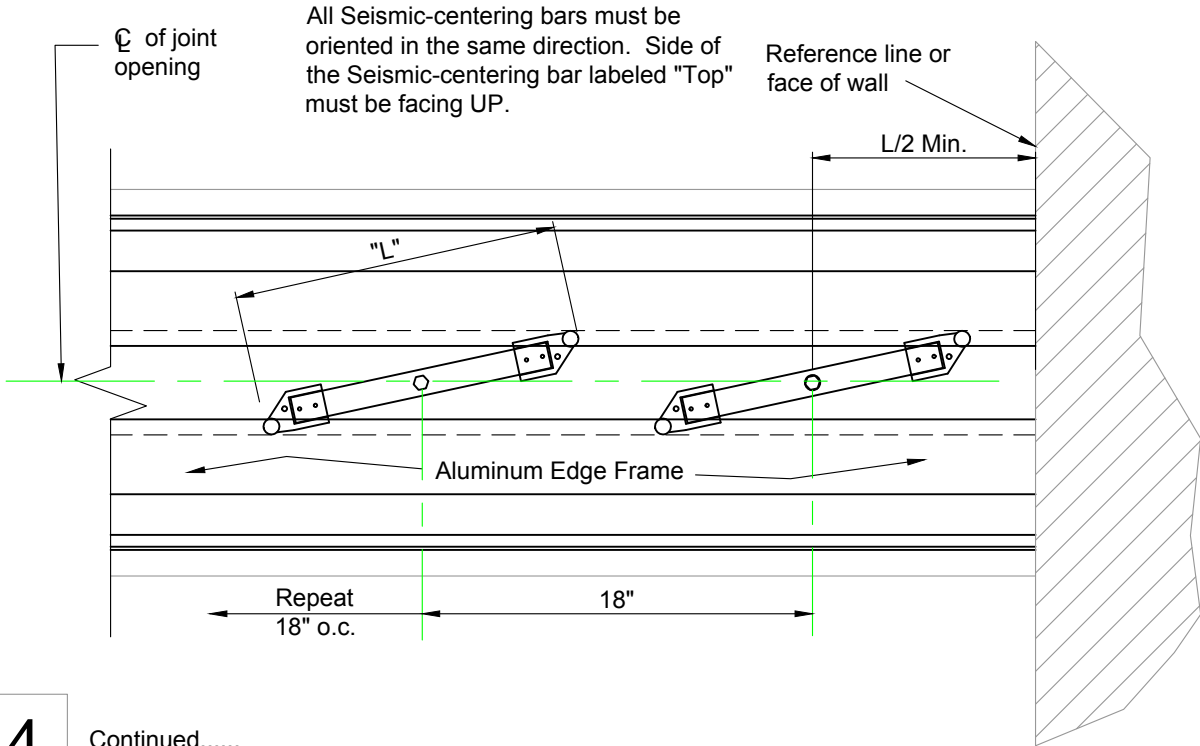

4

Continued.....

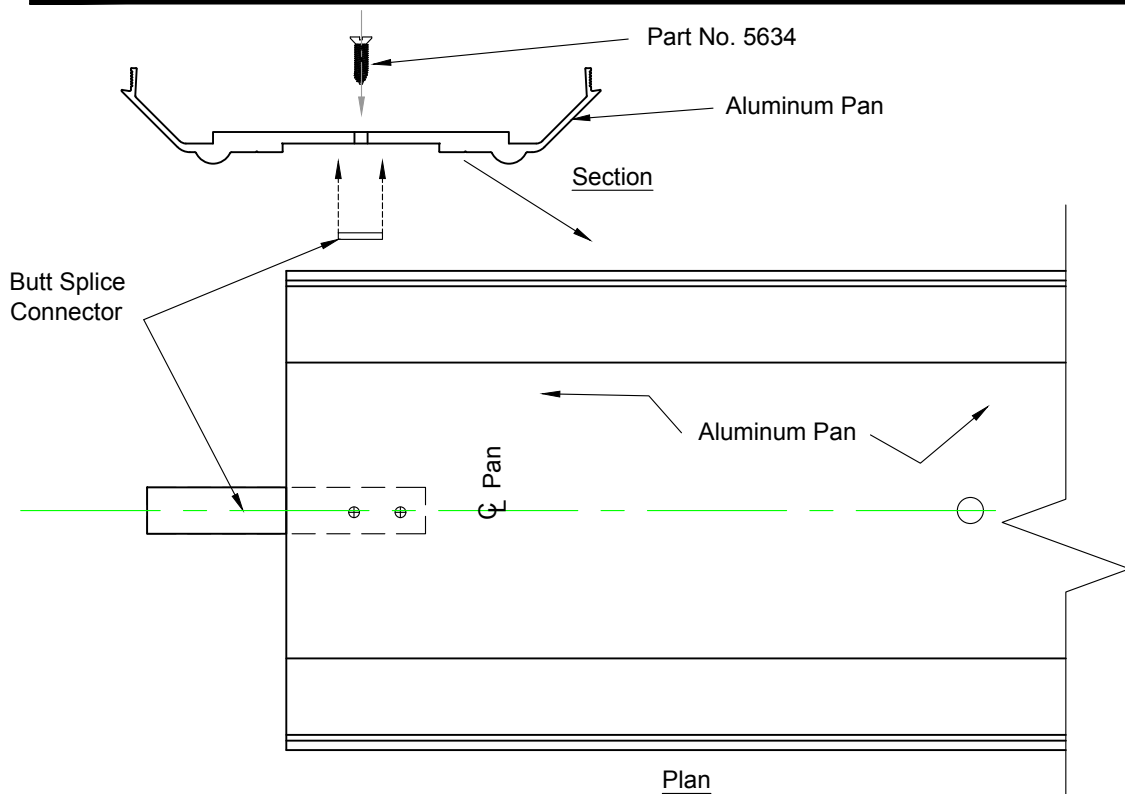

5

After aluminum edge frames and Seismic-centering bars are installed, start adding butt splice connectors to one end of each aluminum pan using factory holes provided and part no. 5634 (Screw 1/4" x 1" FTPN)

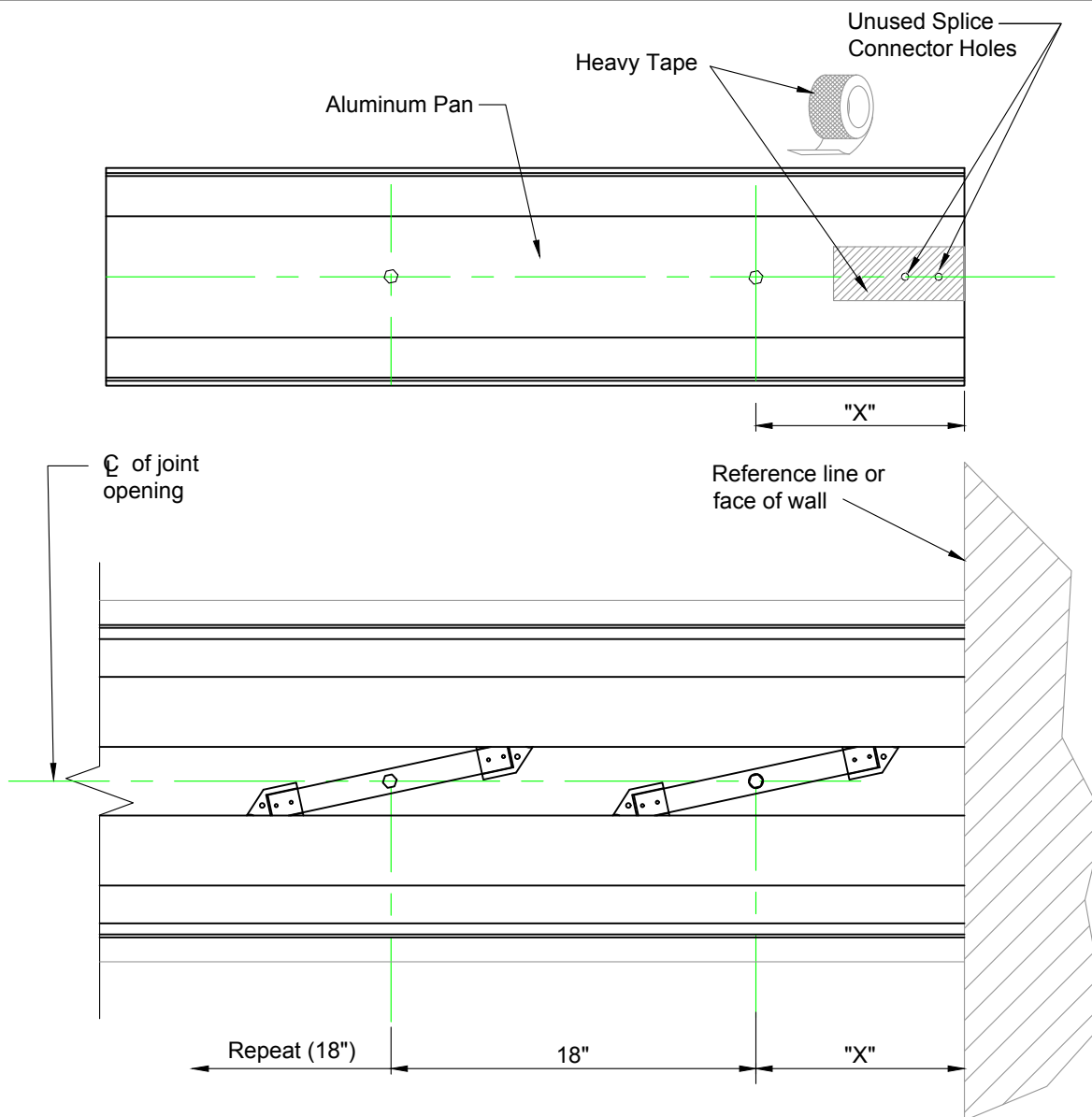

6

Use Heavy Tape to cover un-used splice connector holes (this will be at the first aluminum pan to be installed against the wall). Take Measurement "X" from Aluminum Pan and align first self-centering bar to this dimension as shown. This step is to double check for accuracy before installing the Aluminum Pan

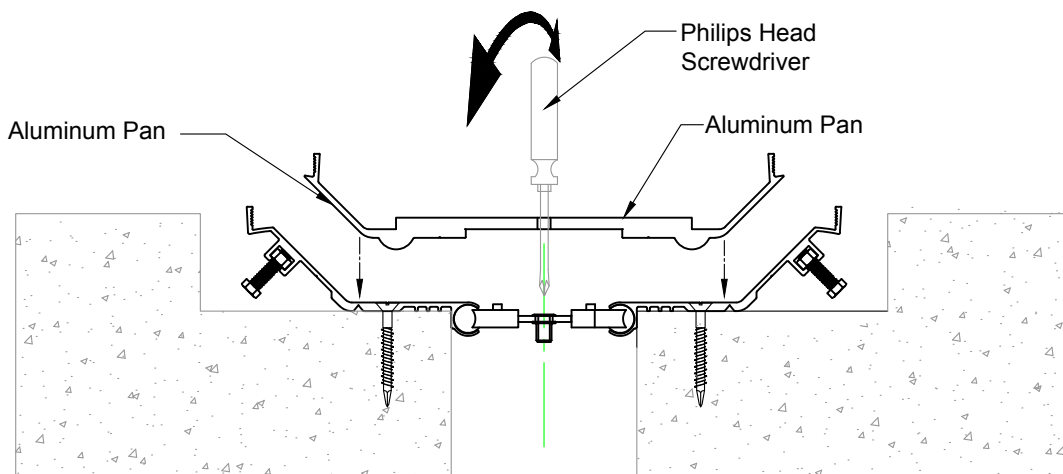

7

Center the Aluminum Pan on joint opening while keeping end of pan snug with wall / reference line. Use philips head screwdriver to fine-tune alignment of seismic-centering bars to associated pre-drilled holes in Aluminum Pan.

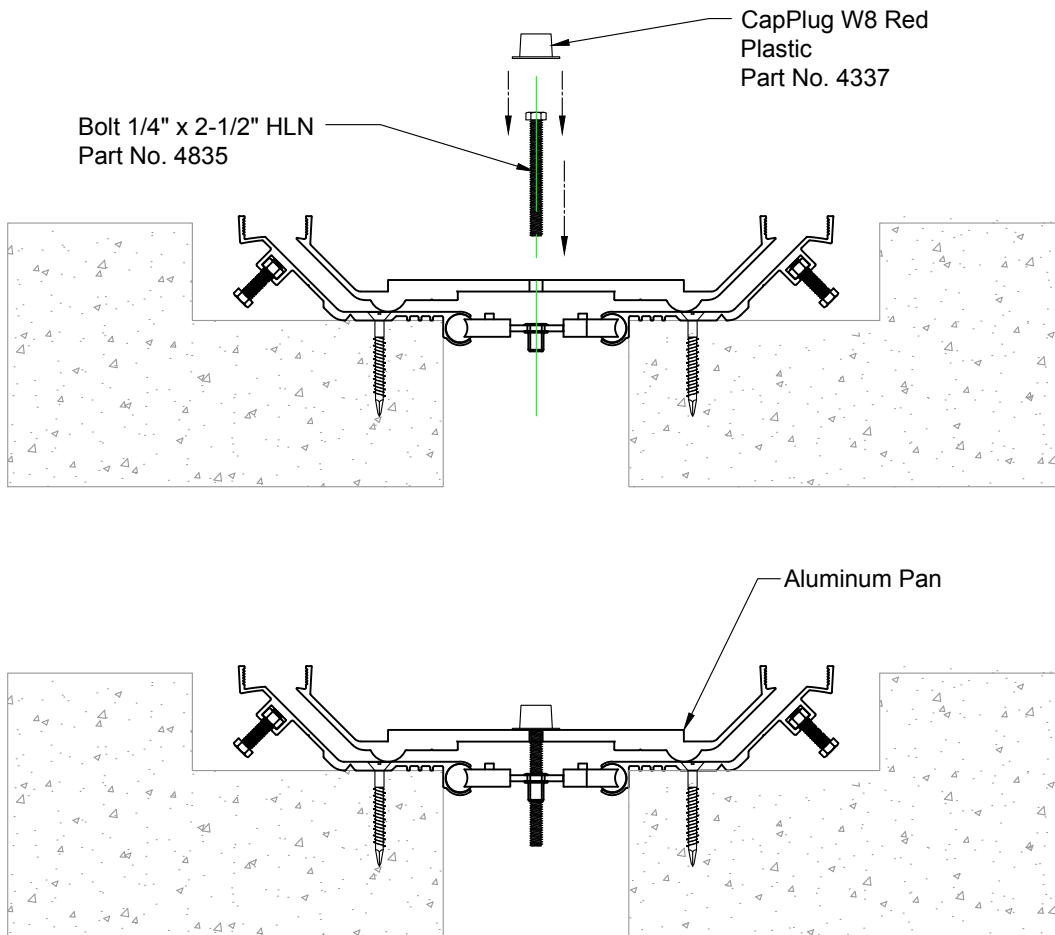

Insert Part No. 4835 through pre-drilled holes in Aluminum Pan and seismic-centering bars and tighten to \_\_\_\_\_ inch-lbs. Cover bolt heads with CapPlugs (Part no. 4337).

8

**Note:**

Installation Tip: Calibrate battery operated drill / driver to proper inch-lb setting. Periodically inspect for proper torque utilizing "clicker" wrench.



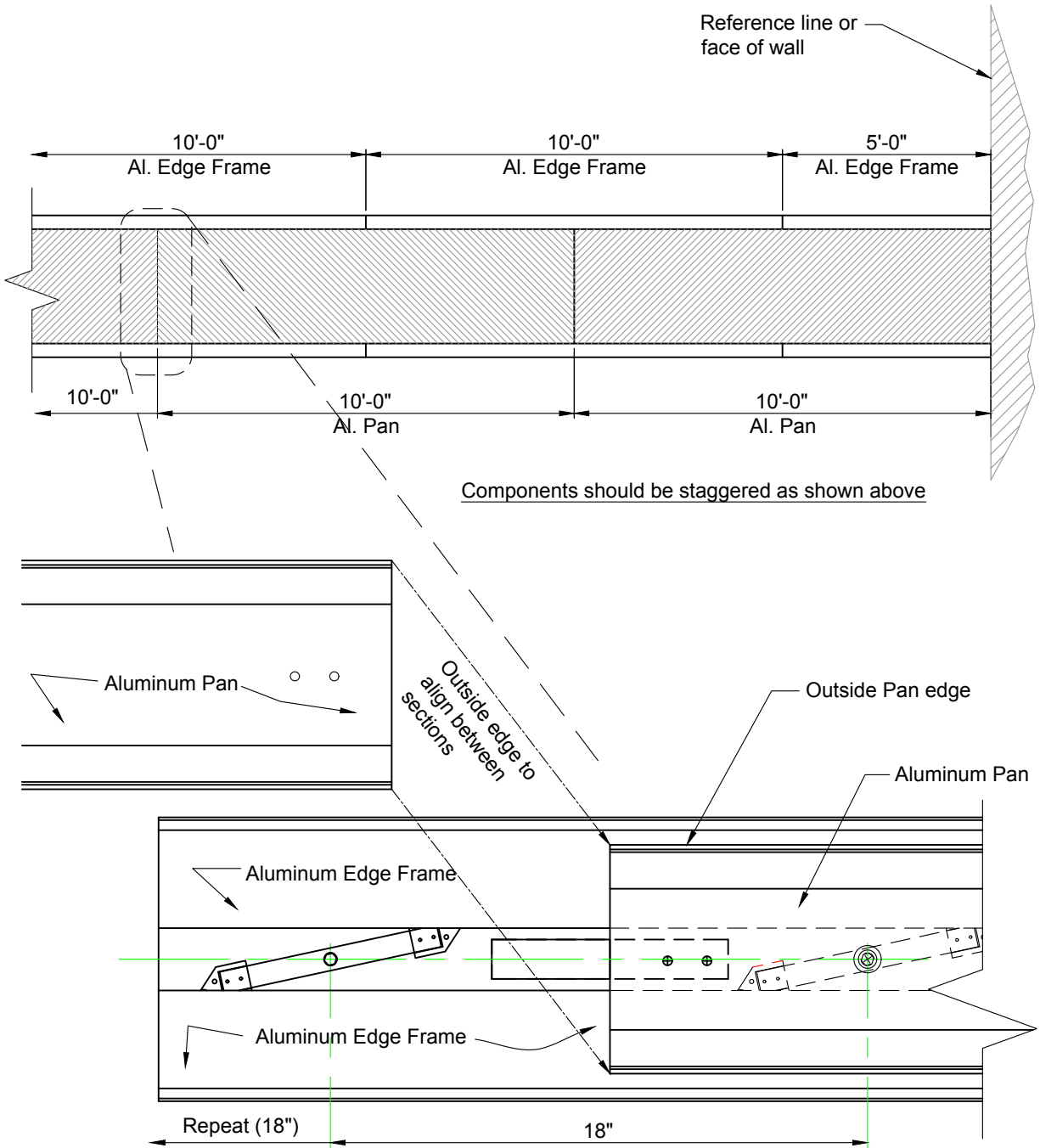

9

Repeat steps 5, 6, & 7 to align seismic-centering bars for next section of Aluminum Pan. Be sure to start threading seismic-centering bars for this section (do not completely tighten seismic-centering bars (as noted in step 8) until Step 10 is complete). Ensure Aluminum pan sections butt tightly together and that the outside edges align from section to section.

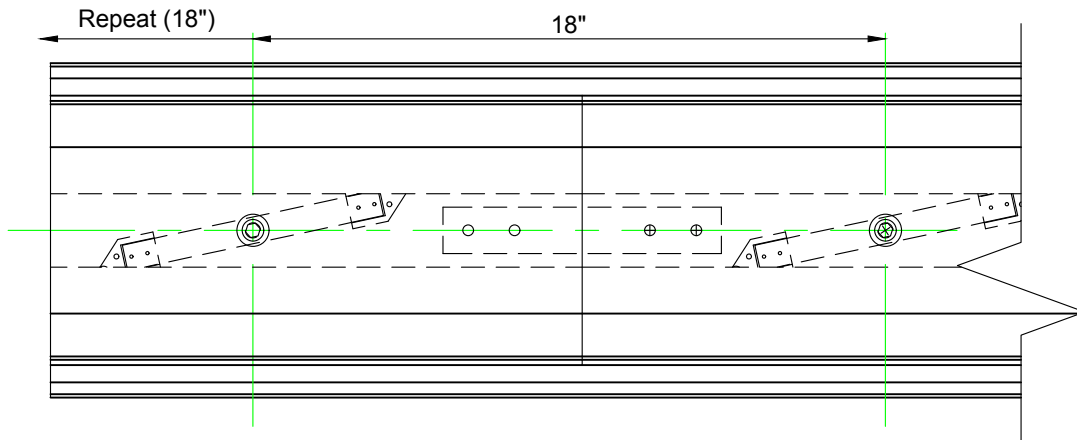

Nail  
Setter



Hole  
Punch

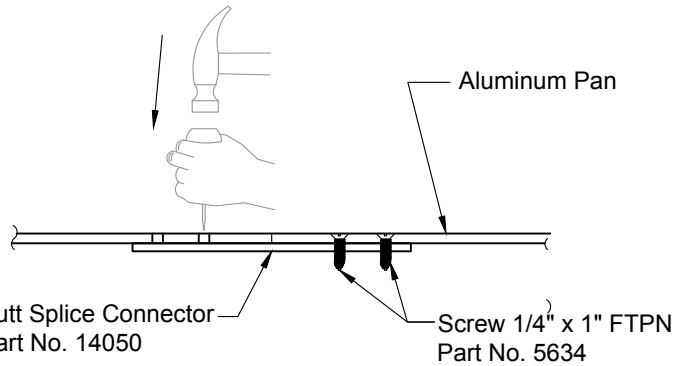

Butt Splice Connector  
Part No. 14050

Screw 1/4" x 1" FTPN  
Part No. 5634

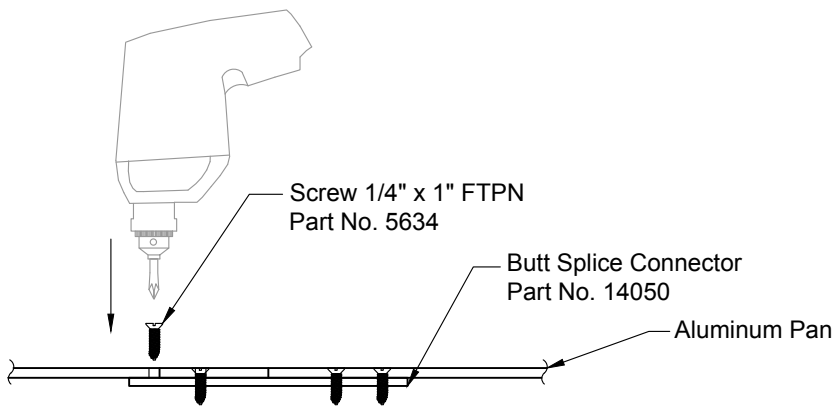

Screw 1/4" x 1" FTPN  
Part No. 5634

Butt Splice Connector  
Part No. 14050

Aluminum Pan

10

Using the splice connector holes in the Aluminum Pan as a guide, firmly tap in guide marks into the aluminum splice connector below utilizing either a nail setter or hole punch. Pre-drill 3/16" dia. pilot hole in connector. Use self tapping screws (Part No. 5634) to complete splicing of pan systems together. Tighten seismic-centering bar bolts in newly spliced Aluminum Pan Section.

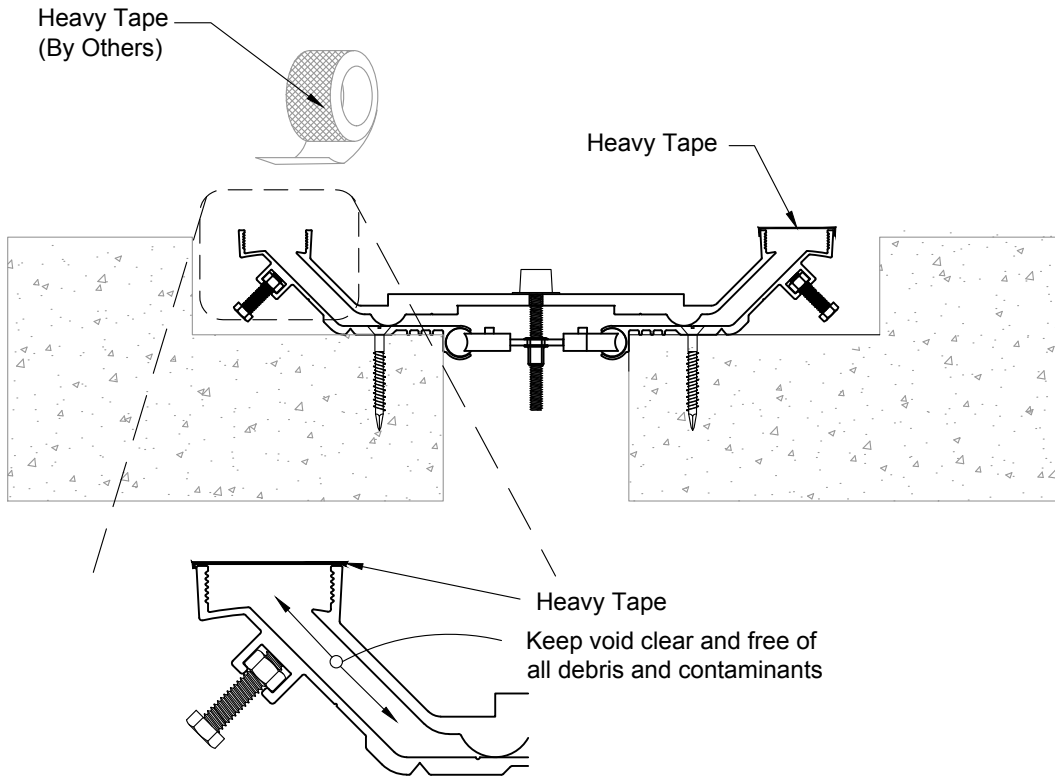

11

Use heavy tape continuously to protect joint opening through the next final steps.

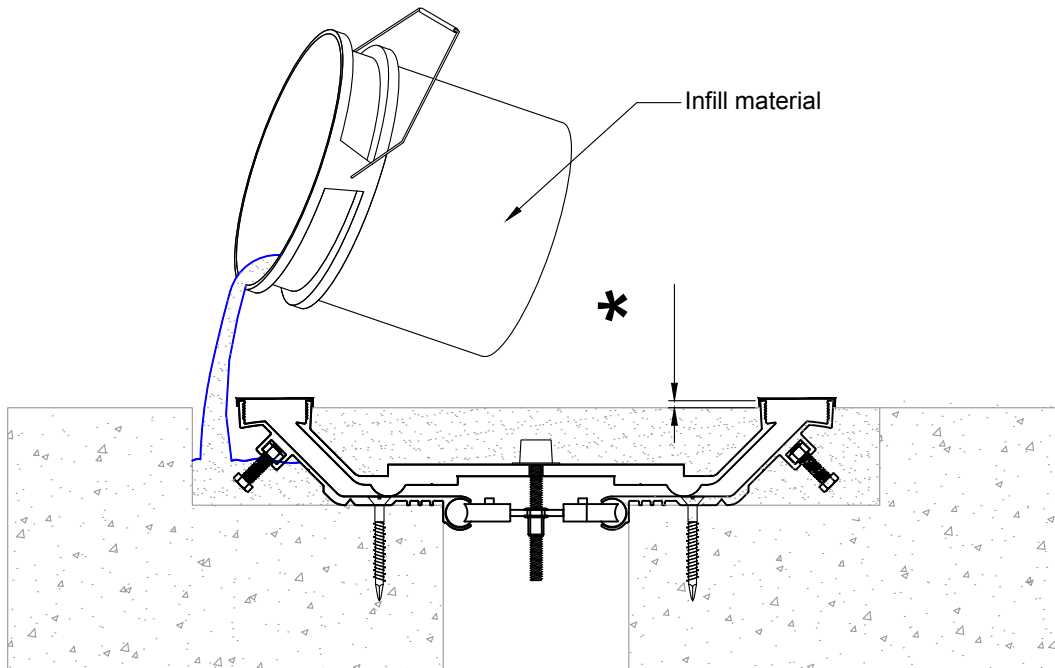

12

Pour infill material into blockout voids and Pan cavity.

\* **Warning!** - Leave required recess for finish floor finish material thickness and proper placement

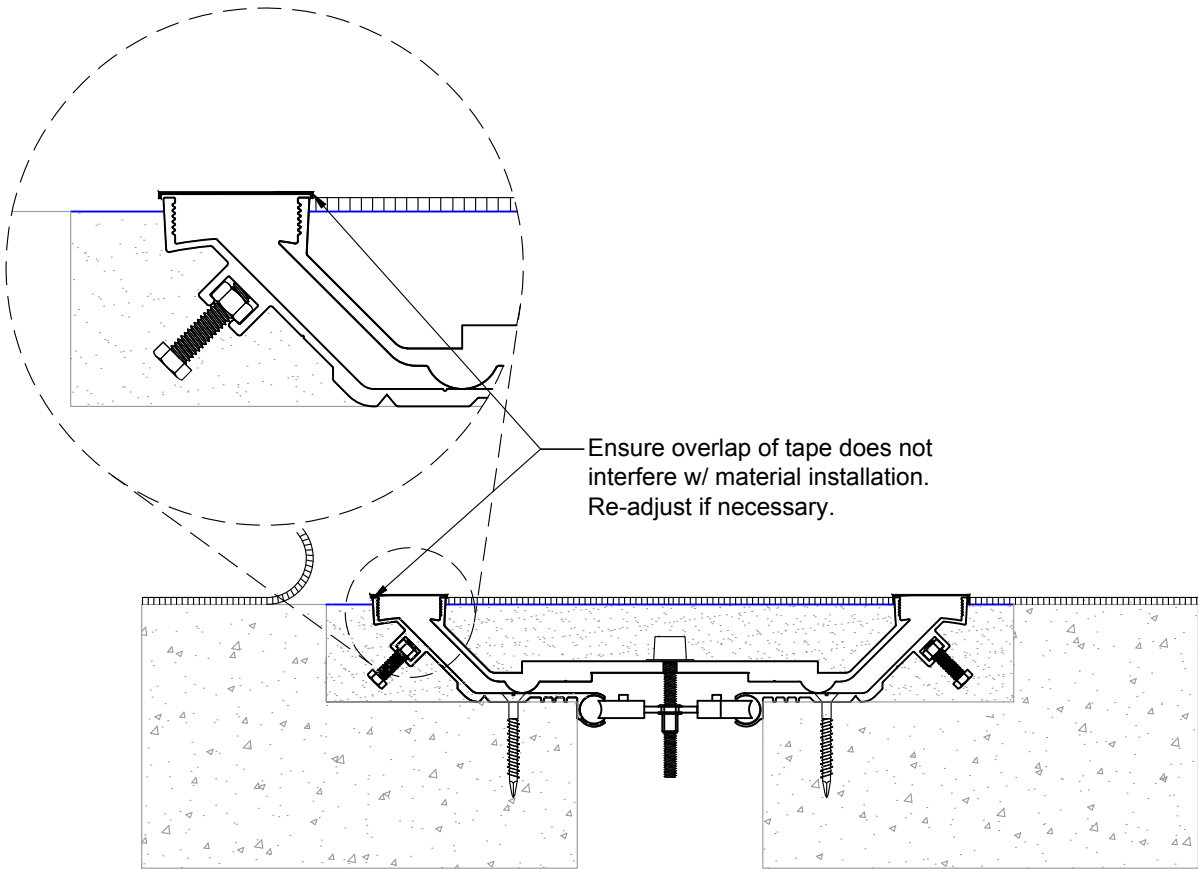

Carpet Shown - Finish floor material not by Emseal.

**13**

Install finished floor material. Be sure to keep joint opening protected (See Step 11)

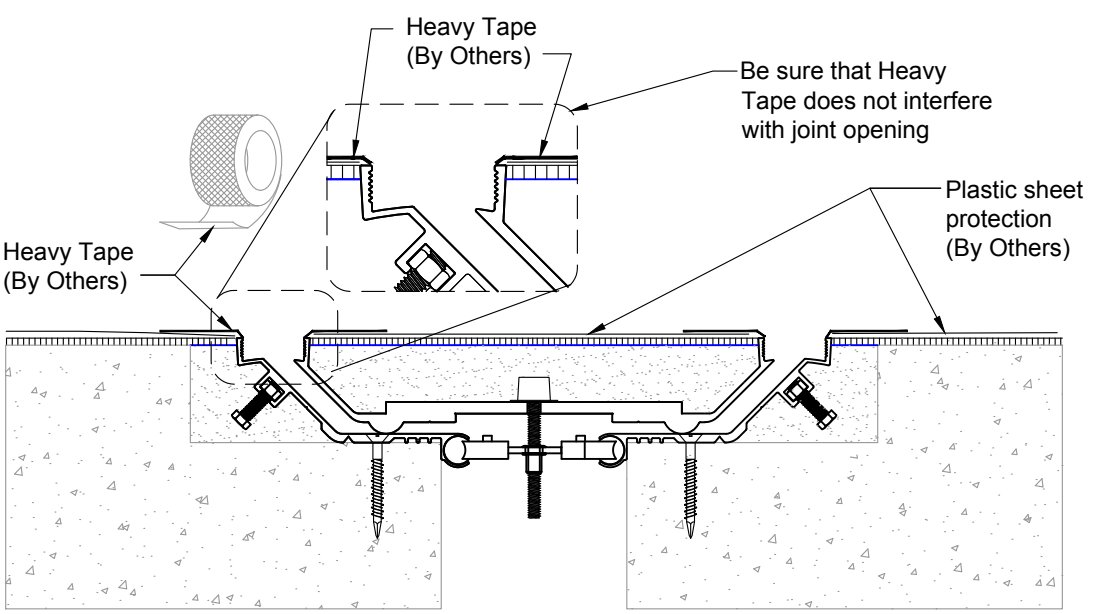

**14**

Remove Heavy Tape from joint opening. Protect surrounding finish floor material using Heavy Tape and Heavy Gauge Plastic Sheeting

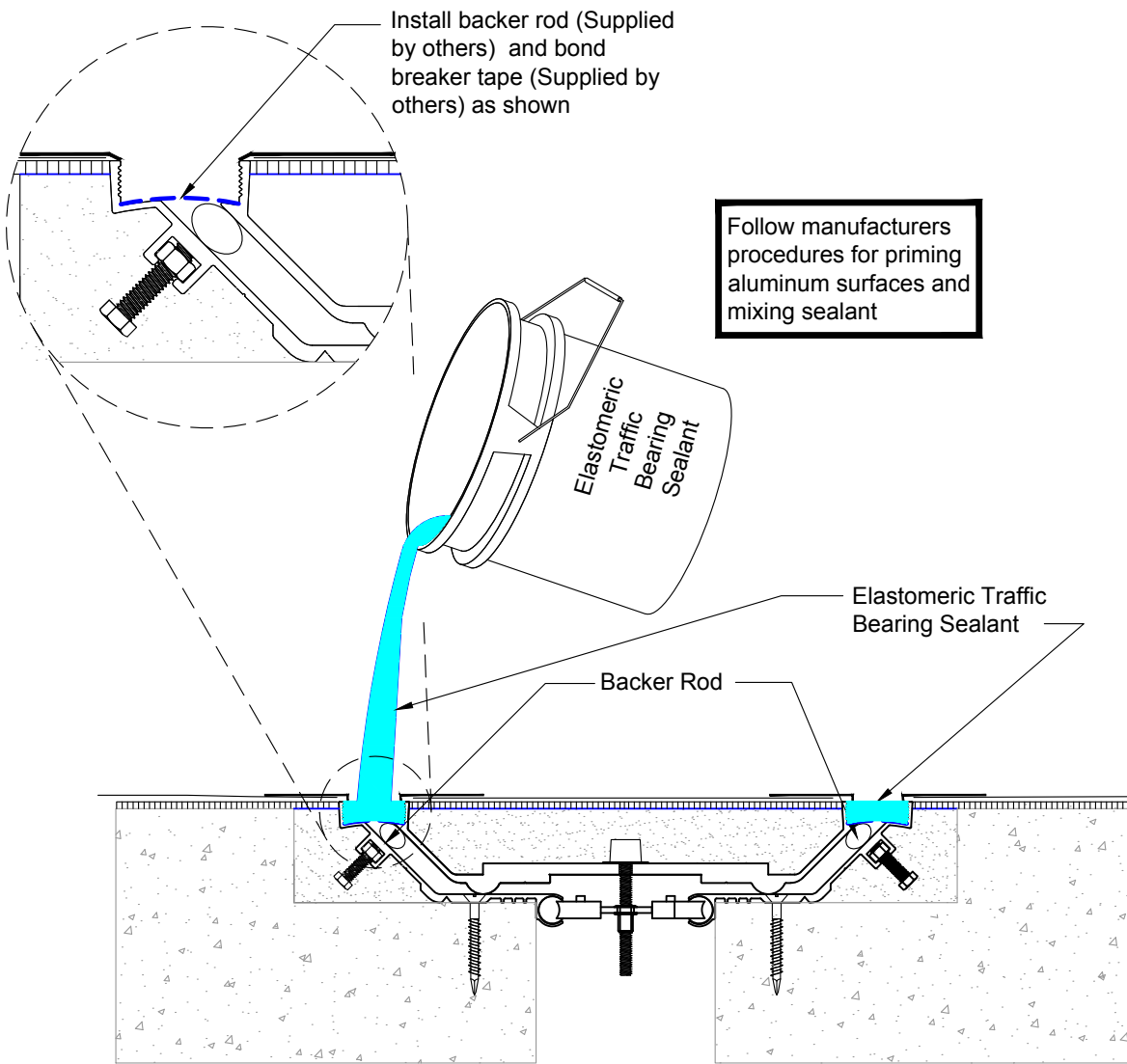

**15** Install Backer Rod, Bond Breaker Tape

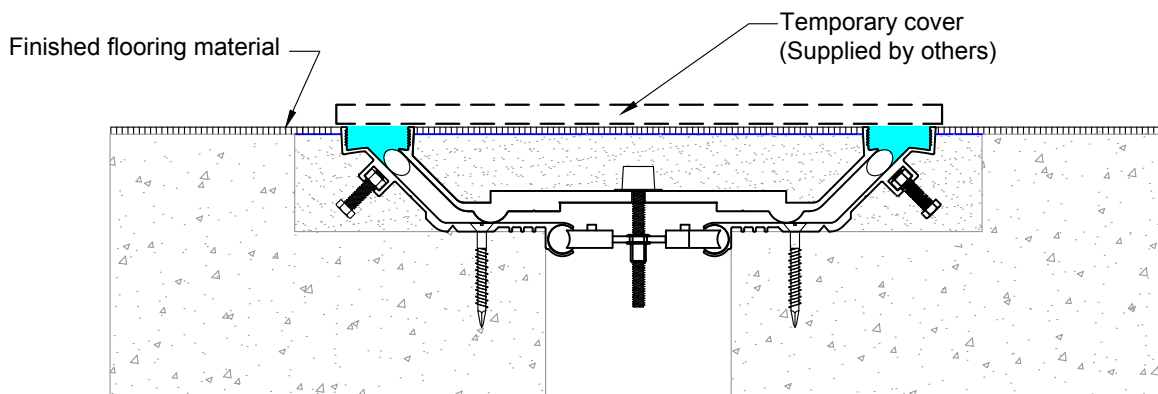

**16** Installing contractor shell cover and protect the finished expansion joint assembly from damage during installation of finish floor materials. The expansion joint assembly is a finished product. Damage to expansion joint finishes and components are excluded from warranty

# Installation procedure for corner condition

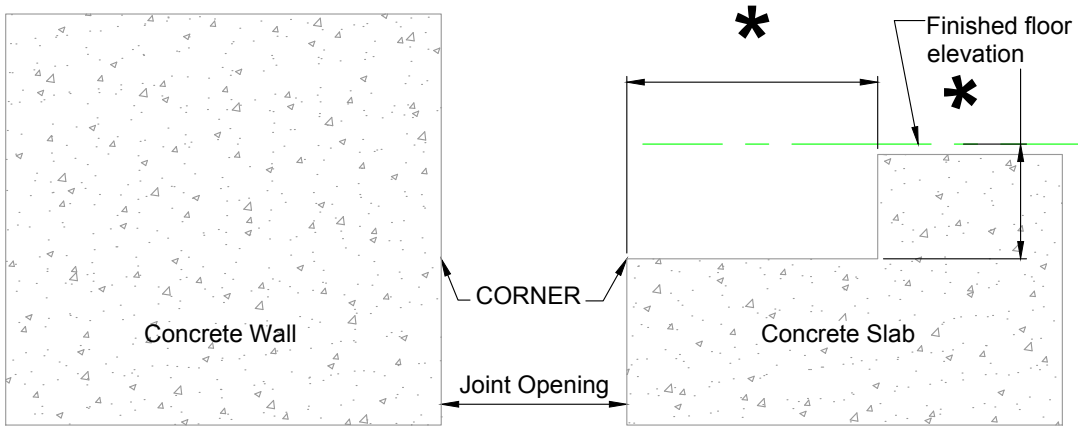

**1** Prior to beginning work, installer shall inspect opposing concrete slabs, corners and blockouts for acceptability. For repair (if required) refer to step 2, also, measure joint opening for proper size as called for on shop drawings or Cad detail.

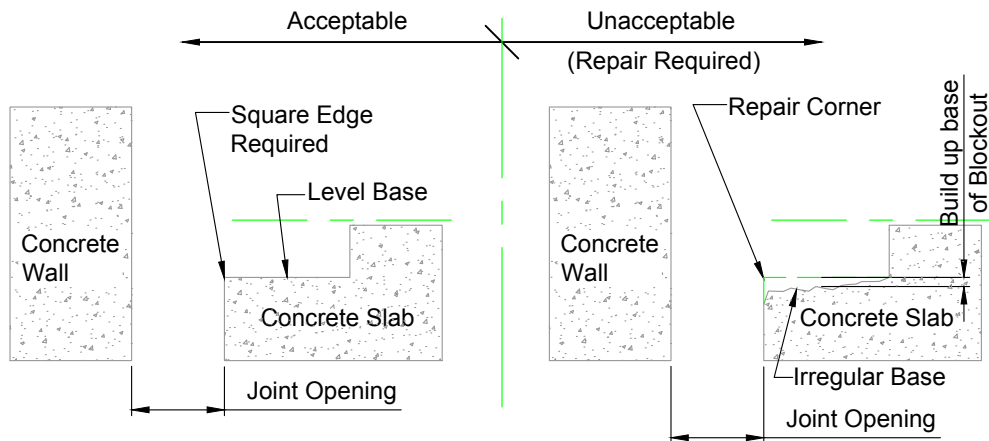

**2** Repair corner of concrete slab and blockout base following manufacturers written instructions.

Figure 3a.1

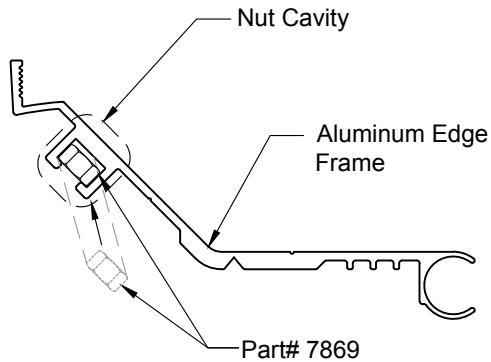
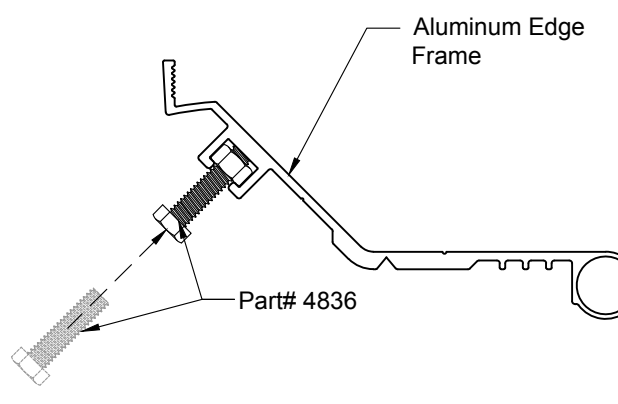
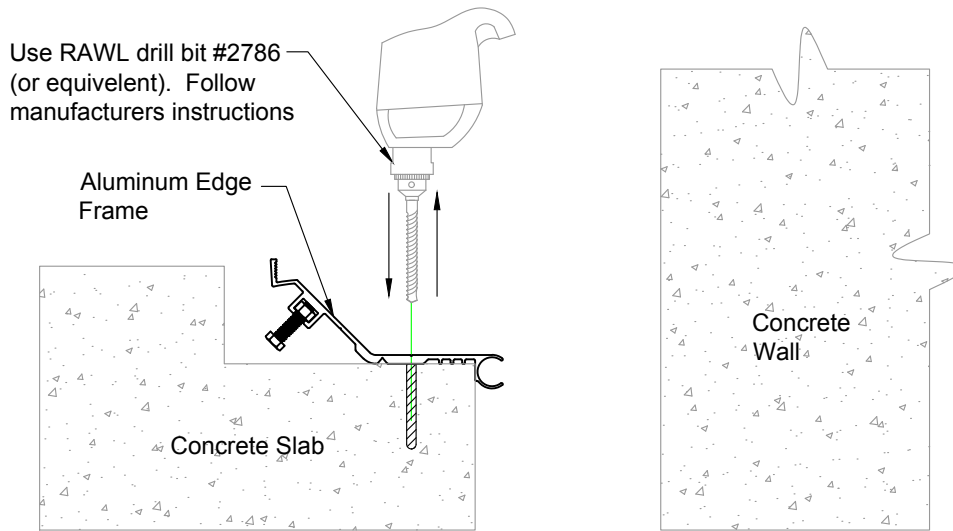

Figure 3a.2



**3a** Figure 3a.1 - Insert (4) ZINC PLATED NUTS (Part # 7869) into NUT CAVITY of ALUMINUM EDGE FRAME.

Figure 3a.2 - Thread Bolt 1/4" x 1" HLN (Part # 4836) into each ZINC PLATED NUT, spacing at 36" on center (starting 6" from either end). Tighten until bolts are secure.



3b

Utilizing pre-drilled holes in Aluminum edge frame assembly as a template, drill pilot holes using a 3/16" TAPPER Masonry drill Bit. Use two 5 foot Aluminum Edge frame sections (1 on each side of joint opening) when starting a run of Wabo® Seismic Pan. See step 6.

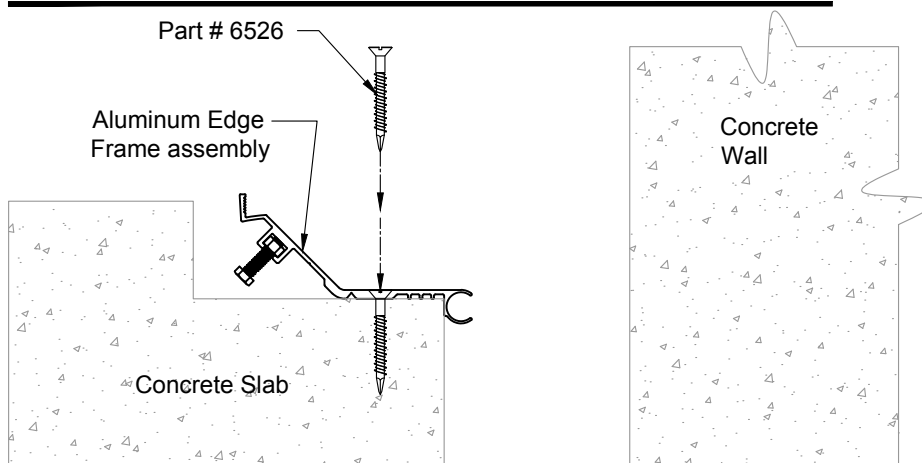

3c

Fasten Aluminum Edge Frame Assembly securely using Threaded Anchor Rawl Tapper #2764 1/4" x 2-1/4" (Part No. 6526) Utilizing predrilled countersunk holes.

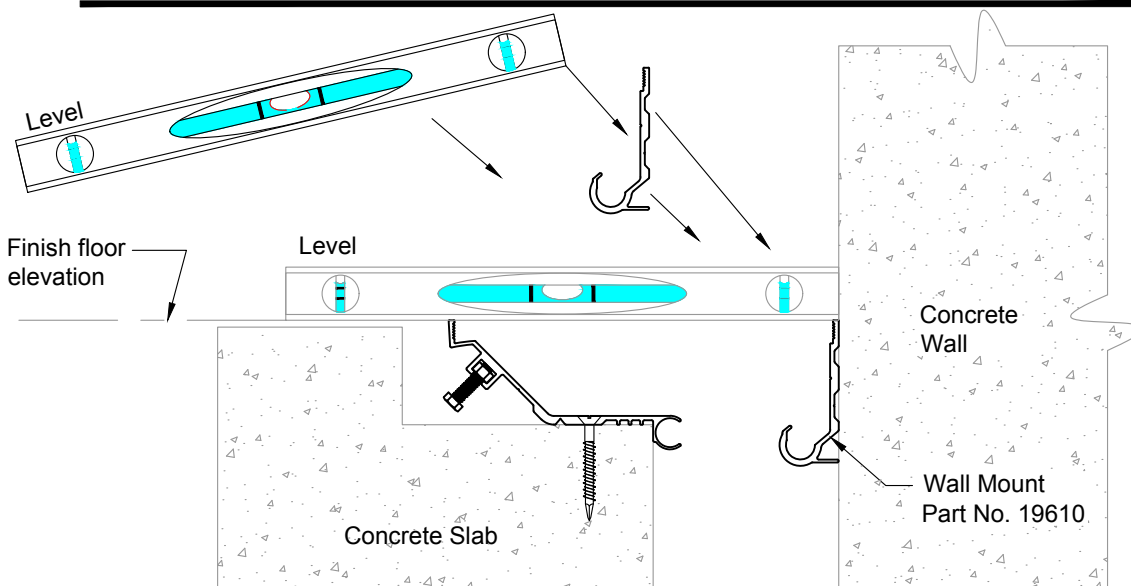

4a

In preparation for fastening Wall Mount Extrusion (Part No. 19610), hold ext against wall and making sure that it is LEVEL with the adjacent Aluminum Edge Frame Assembly. Snap a chalk line to insure level installation. Use 5 foot piece Wall Mount at start of each joint run.

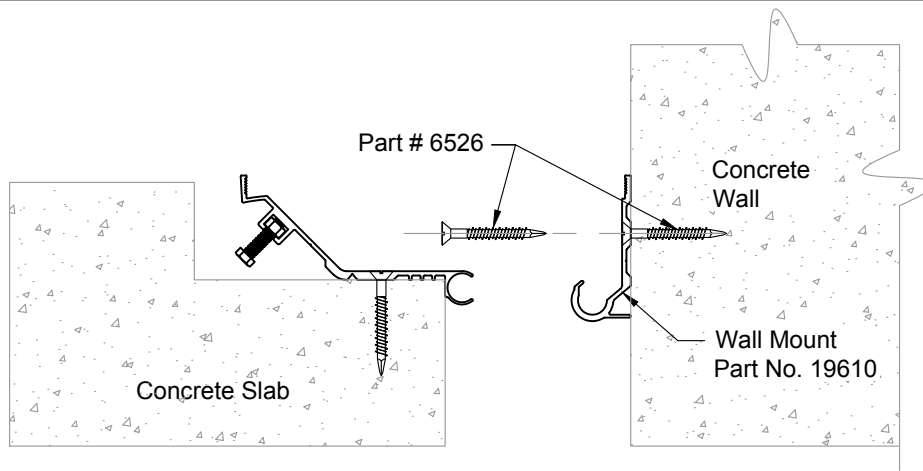

**4b**

Fasten Wall Mount with part no. 6526 utilizing pre-drilled countersunk holes.

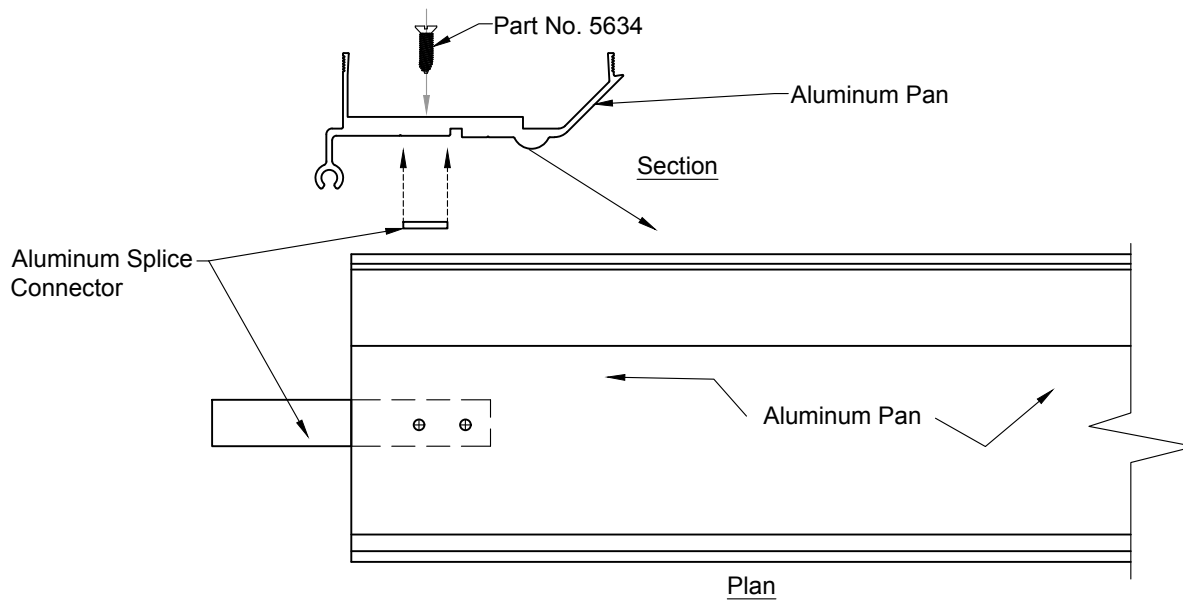

**5**

After aluminum edge frames and Seismic-centering bars are installed, start adding butt splice connectors to one end of each aluminum pan using factory holes provided and part no. 5634 (Screw 1/4" x 1" FTPN)

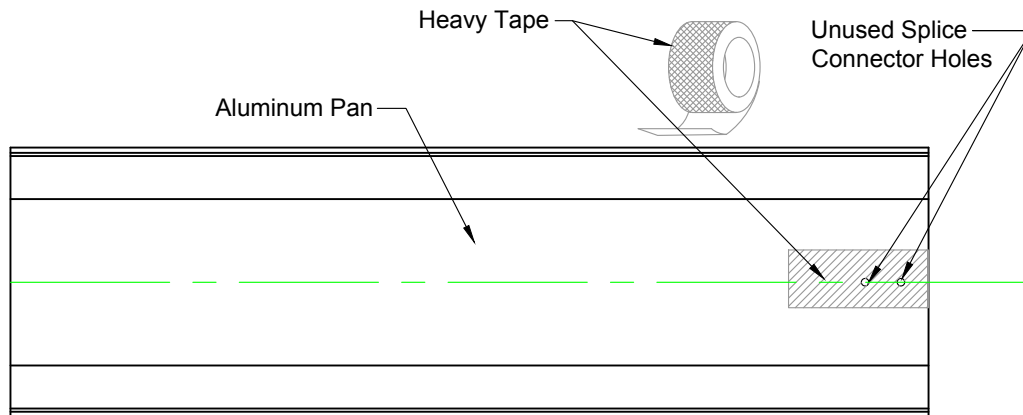

**6**

Use Heavy Tape to cover un-used splice connector holes (this will be at the first aluminum pan to be installed against the wall).



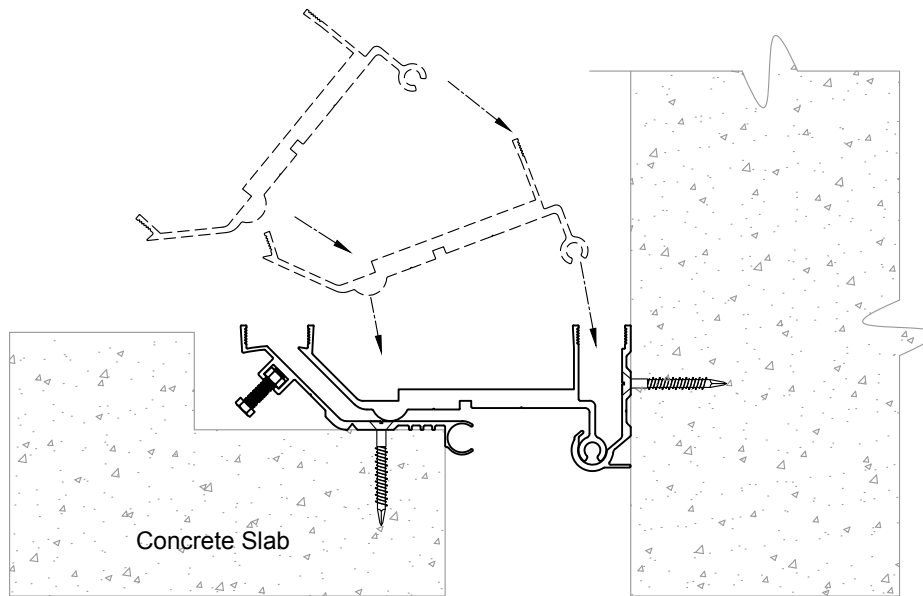

7

Gently set Aluminum Pans into place as shown above. See **Steps 8 & 9** for splicing procedure

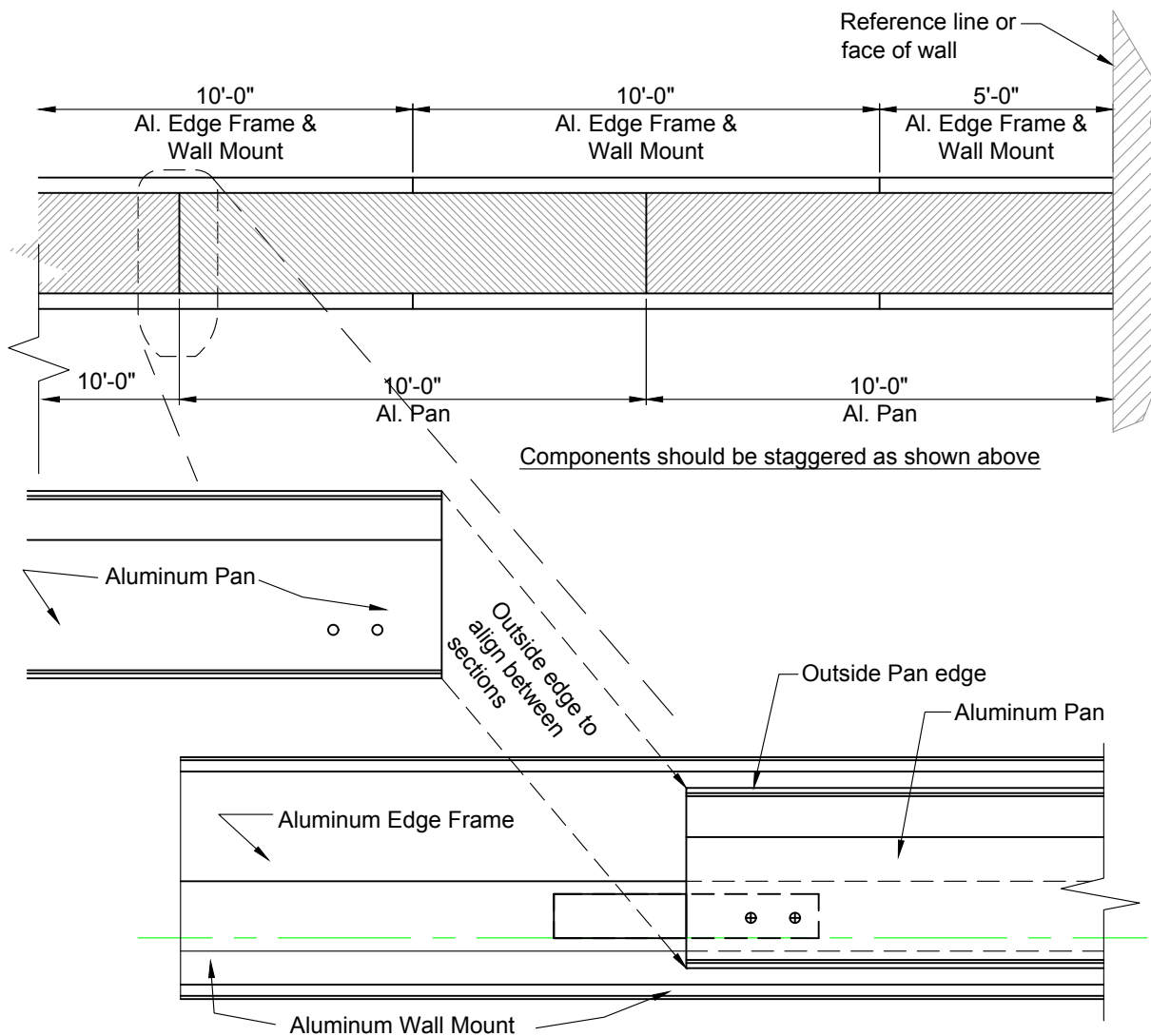

8

Set in next Aluminum Pan snug against previously laid in Aluminum Pan. See Step 9 for splicing the two together. Ensure Aluminum pan sections butt tightly together and that the outside edges align from section to section.

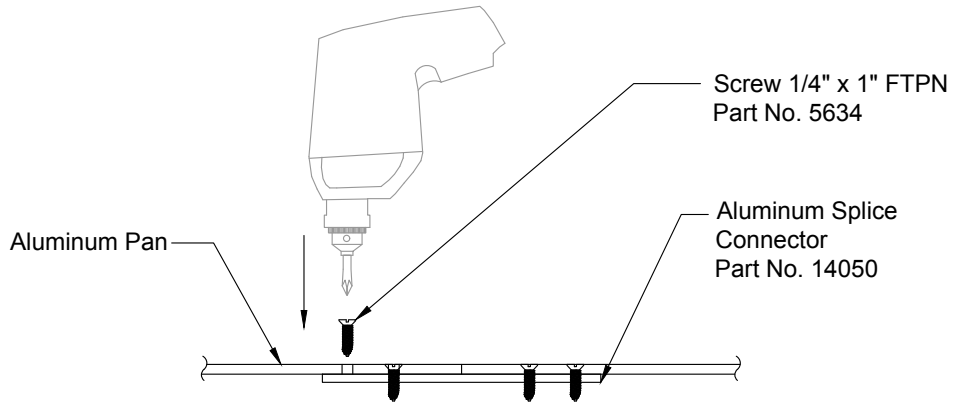
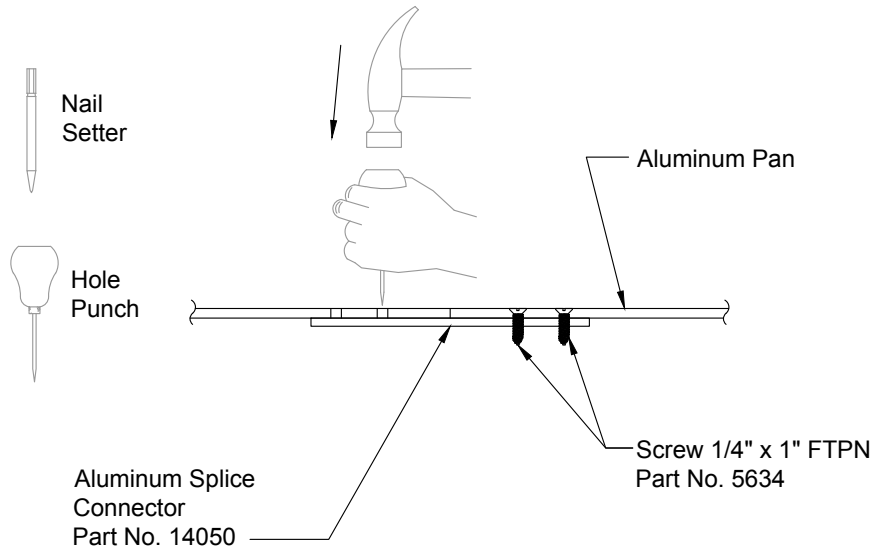
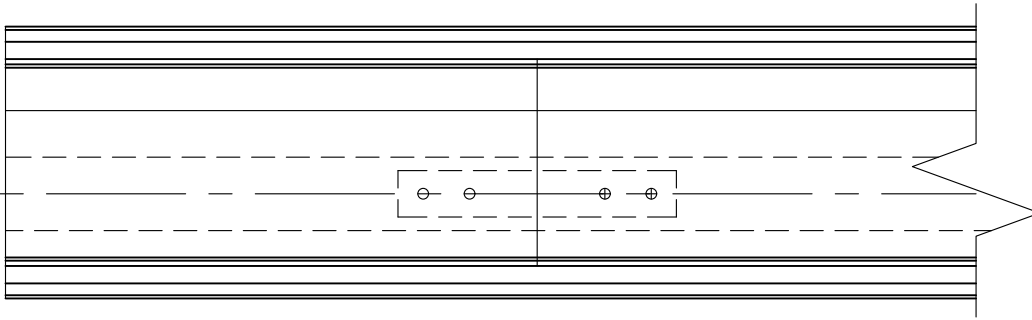

9

Using the splice connector holes in the Aluminum Pan as a guide, firmly tap in guide marks into the aluminum splice connector below utilizing either a nail setter or hole punch. Pre-drill 3/16" dia. pilot hole in connector. Use self tapping screws (Part No. 5634) to complete splicing of pan systems together.

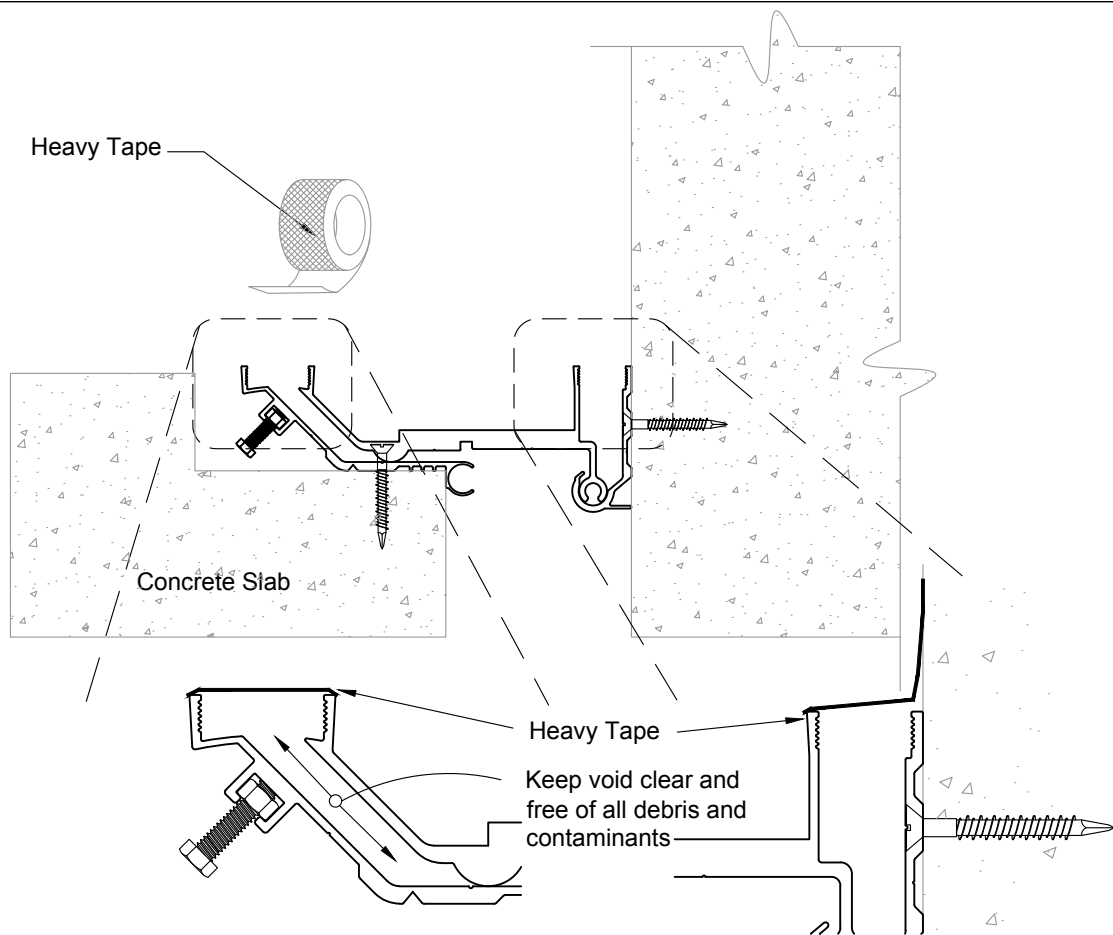

**10** Use heavy tape continuously to protect joint opening through the next final steps.

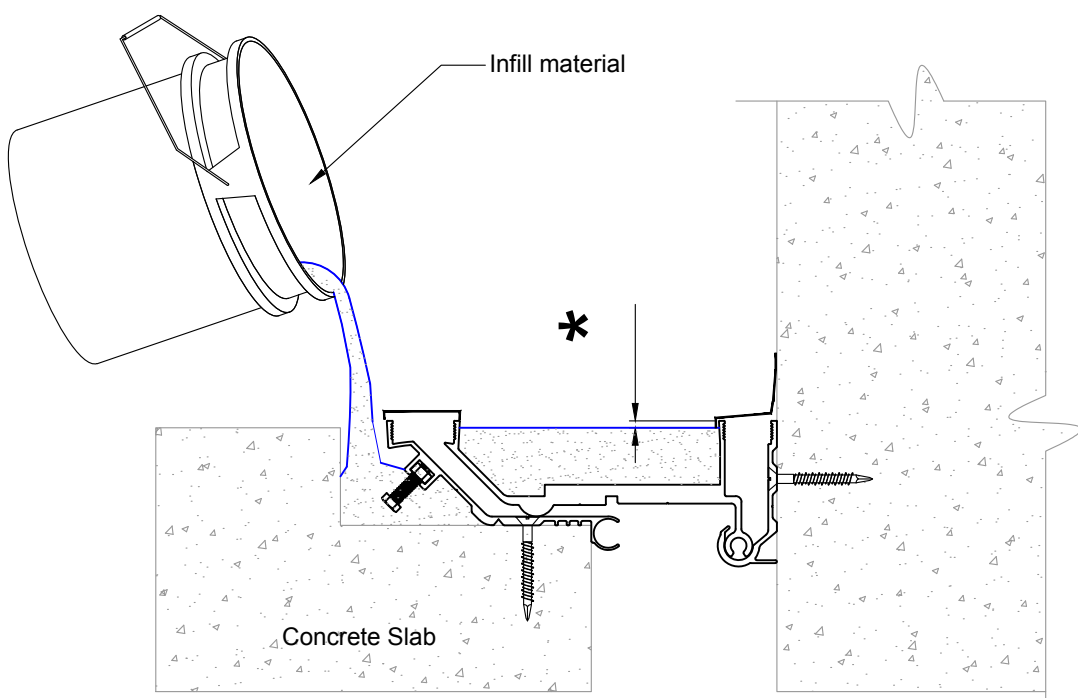

**11** Pour infill material into blockout voids and Pan cavity. \* Warning! Leave required recess for finish floor finish material thickness and proper placement

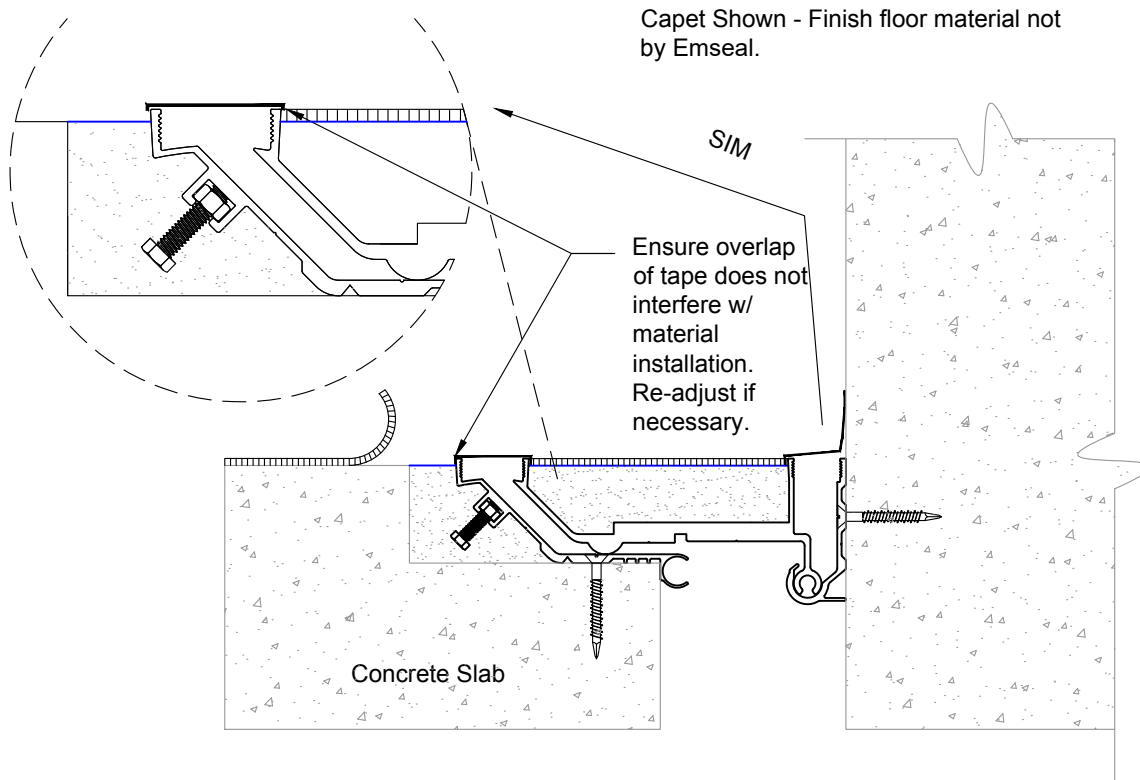

**12** Install flooring material. Keep joint opening protected until surrounding flooring installation is complete

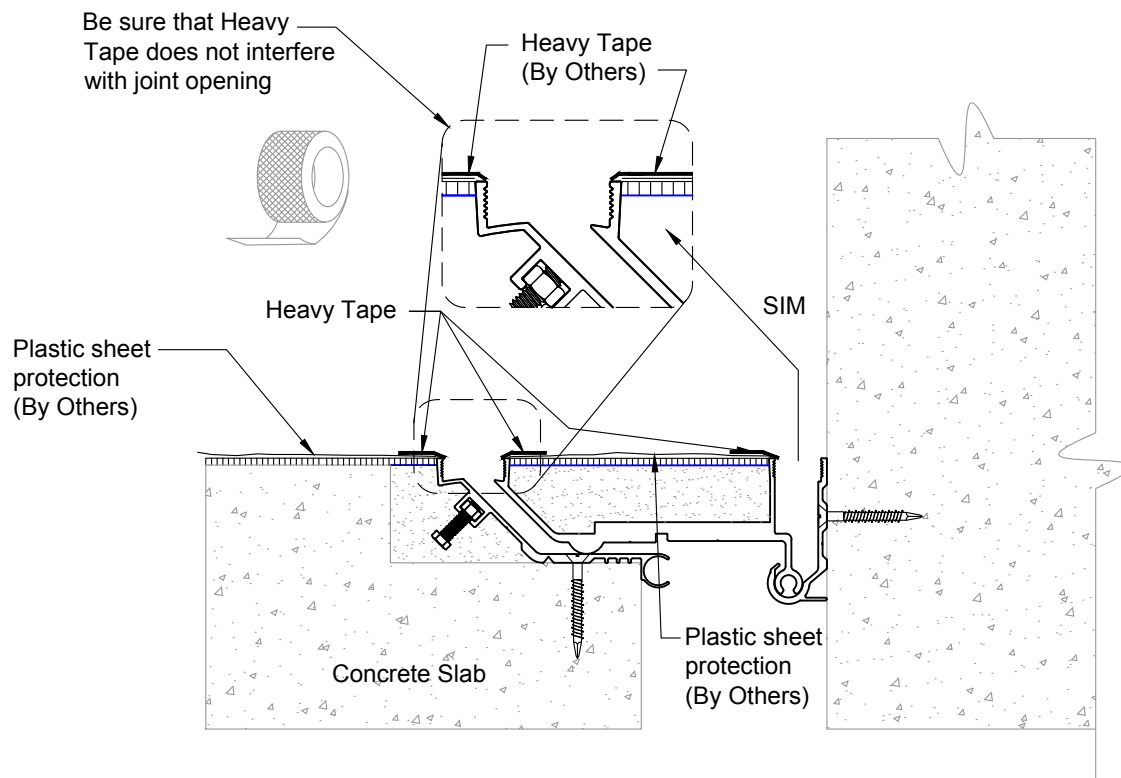

**13** Remove Heavy Tape from joint opening. Protect surrounding finish floor material using Heavy Tape and Heavy Gauge Plastic Sheeting

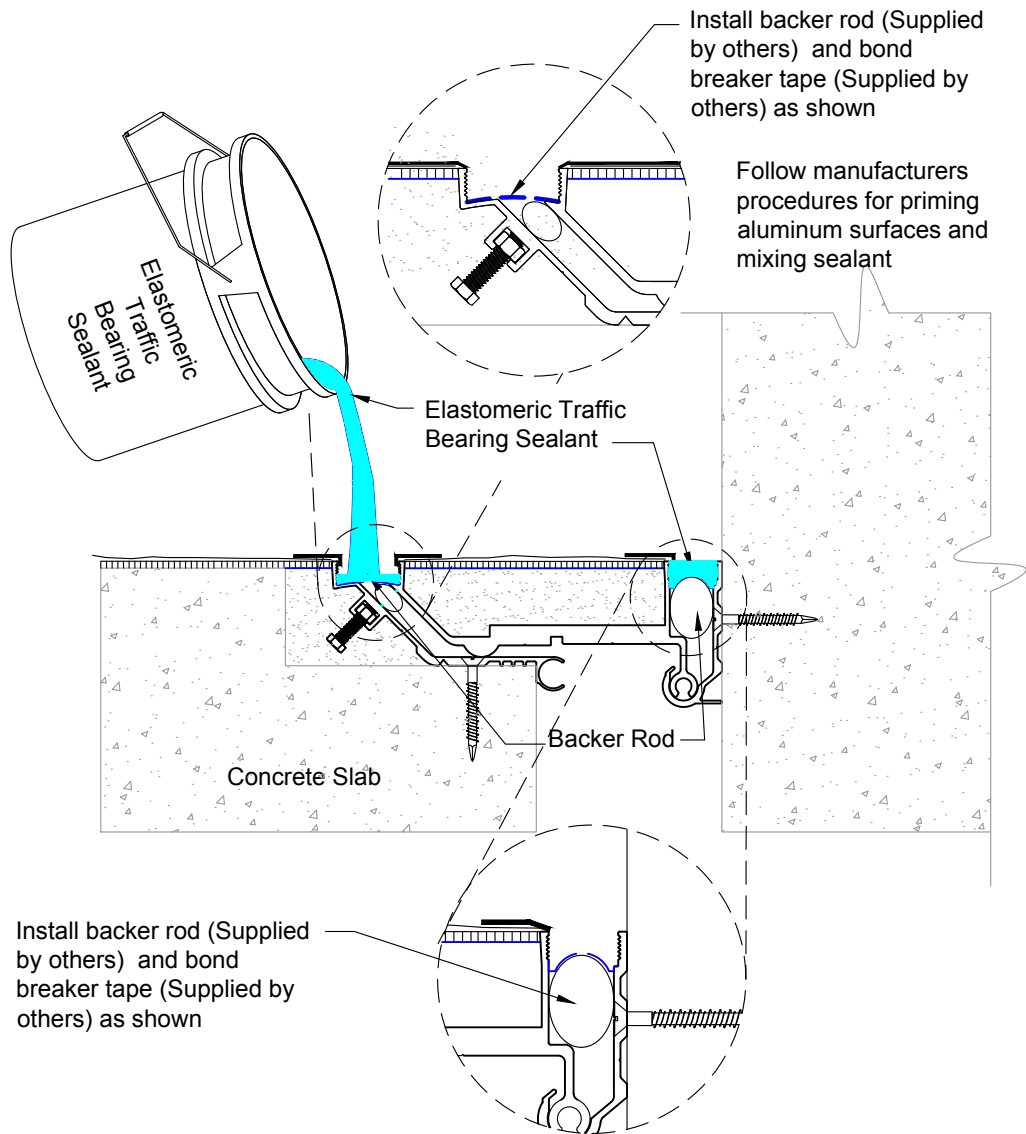

**14** Install Backer Rod, Bond Breaker Tape

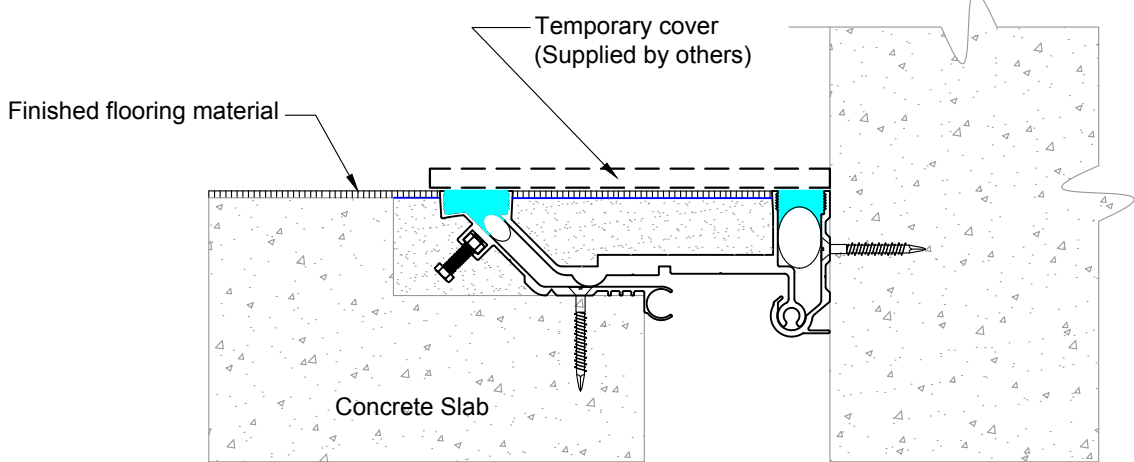

**15** Installing contractor shell cover and protect the finished expansion joint assembly from damage during installation of finish floor materials. The expansion joint assembly is a finished product. Damage to expansion joint finishes and components are excluded from warranty

## Installation procedure: SeismicPan "SPJ" system

Information provided herein, including but not limited to, any drawing, design, photograph, graphic, or statement(s) ("Materials") are proprietary and the property of Sika Emseal ("Company"). Reproduction, translation, or reduction to any electronic medium or machine readable form, in whole or part, is strictly prohibited, except for the express purpose for which it has been furnished, without prior written consent of Company. All Materials contained herein are provided by Company for information purposes only. Company reserves the right to amend or withdraw any information contained in the Materials without notice. All technical or other advice by Company, whether verbal or written, concerning products, or the use of products in specific situations ("Advice") is given by Company and is used at the Users own risk.

Sika Emseal  
25 Bridle Lane, Westborough, MA 01581 USA  
Phone: 508-836-0280 / Fax 508-836-0281  
[www.emseal.com](http://www.emseal.com)  
Rev. 1.0 04-02-2024



BUILDING TRUST

